

Summit Top Rail Range

Summit Nano Round Rail (25x21mm) Series

NANORAIL® 25 X 21MM HANDRAIL

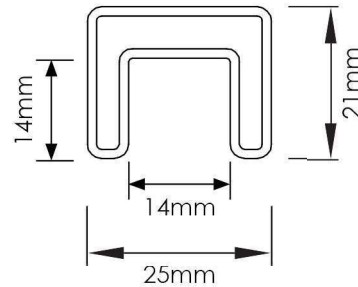

2900mm RHS HANDRAIL, 25 x 21mm

Polish Or Satin Finish

Order Code: **STG-R2900-2521-P** (polish finish)
STG-R2900-2521-S (satin finish)

5800mm RHS HANDRAIL, 25 x 21mm

Polish Or Satin Finish

Order Code: **STG-R5800-2521-P** (polish finish)
STG-R5800-2521-S (satin finish)

SPECIFICATION

- Available in 5800mm or 2900mm lengths: Polish or Satin finish
- Slimline stylish profile – 'Nanorail' - caps over 12mm thick glass
- 1.2mm wall thickness
- 14 x 14mm glazing pocket: silicone onto glass or use in conjunction with glazing rubber
- Stainless Steel 316L - low carbon stainless

NANORAIL® 25 X 21MM JOINER

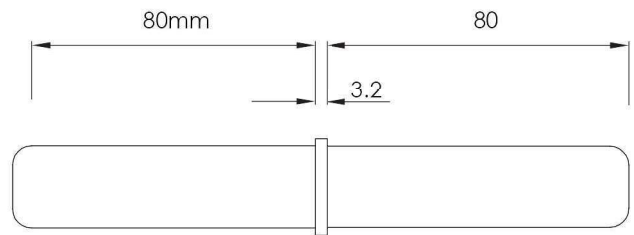

NANORAIL® JOINER

316 STAINLESS STEEL

Polish Or Satin Finish

Order Code: **STG-2521-J-P** (polish finish)
STG-2521-J-S (satin finish)

SPECIFICATION

- In-line rail joiner
- Easy to use tap-in fitting: allows for increased speed of assembly
- Stainless Steel 316; High Polish or Satin finish
- Epoxy glue, weld or drill/tap tube for joining strength

NANORAIL® 25 X 21MM, 90 DEGREE JOINER

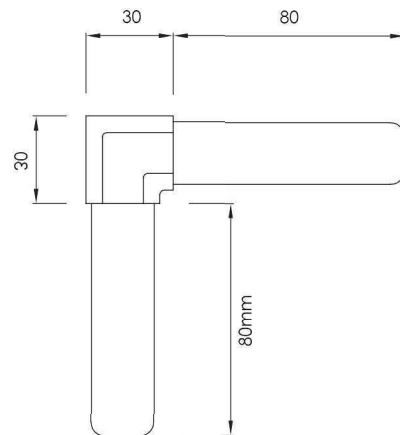

NANORAIL® 90° JOINER

316 STAINLESS STEEL

Polish Or Satin Finish

Order Code: **STG-2521-90J-P** (polish finish)
STG-2521-90J-S (satin finish)

SPECIFICATION

- 90 degree corner joiner ; easy to use tap-in fitting
- Stainless Steel 316; High Polish or Satin finish
- Epoxy glue, weld or drill/tap tube for joining strength

STAINLESS STEEL HANDRAIL

Summit Top Rail Range

NANORAIL® SWIVEL HORIZONTAL JOINER

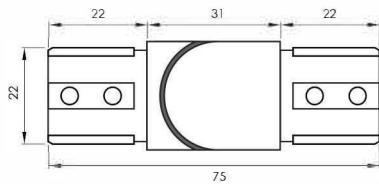

NANORAIL® HORIZONTAL JOINER

316 STAINLESS STEEL

Polish Or Satin Finish

Order Code: **STG-2521-HJA-P** (polish finish)
STG-2521-HJA-S (satin finish)

VARIABLE ANGLE

SPECIFICATION

- Variable angle horizontal joiner
- From straight rail, achieve up to 45 degrees left or right angle joining
- Epoxy glue, weld or drill/top tube for joining strength

NANORAIL® SWIVEL VERTICAL JOINER

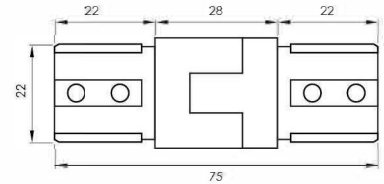

NANORAIL® VERTICAL JOINER

316 STAINLESS STEEL

Polish Or Satin Finish

Order Code: **STG-2521-VJA-P** (polish finish)
STG-2521-VJA-S (satin finish)

VARIABLE ANGLE

SPECIFICATION

- Variable angle vertical joiner
- From straight rail, achieve up to 45 degrees upwards & downwards
- Ideal for staircase installation

NANORAIL® 25 X 21MM END CAP

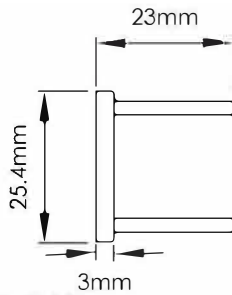

NEW ALSO AVAILABLE SLOTTED END CAP



HIDDEN FIXING

STG-2521-SC-P/S
(polish or satin finish)

- Includes screw with bolt head
- Rail with slotted end cap simply drops over exposed screw head providing hidden fixing

NANORAIL® END CAP

316 STAINLESS STEEL

Satin Or Polish Finish

Order Code: **STG-2521-EC-P** (polish finish)
STG-2521-EC-S (satin finish)

SPECIFICATION

- End cap; easy to use tap-in fitting
- Stainless Steel 316; High Polish or Satin finish
- Epoxy glue, weld or drill/top tube for joining strength

NANORAIL® 25 X 21MM WALL PLATE

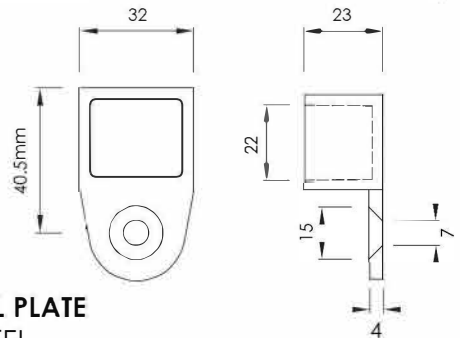

NANORAIL® WALL PLATE

316 STAINLESS STEEL

Satin Or Polish Finish

Order Code: **STG-2521-WP-P** (polish finish)
STG-2521-WP-S (satin finish)

SPECIFICATION

- Bracket can be affixed to wall/post
- 25 x 21mm tube fits into opening (female fit)
- Stainless Steel 316; High Polish or Satin finish
- Epoxy glue, weld or drill/top tube for joining strength

NANORAIL® GLAZING RUBBER



NANORAIL® GLAZING RUBBER

Order Code: **STG-SP1109-30**

SPECIFICATION

- Assists in the installation of NANORAIL to 12mm glass: suggested to use in conjunction with silicone
- Thin U profile RUBBER - 30 Metre Roll - provides for a tight fit
- Used also as a barrier between glass edge and stainless steel handrail

BOSTIK V60 GLAZING SILICONE



BOSTIK V60 TRANSLUCENT GLAZING SILICON 300G

Order Code: **FB-V60**

SPECIFICATION

- Architectural grade high performance glazing silicon
- Neutral cure sealant specially formulated; skins quickly & provides long term performance
- Excellent adhesion & flexibility
- Seals water tight - UV & weather resistant

DEVCON 2 PART EPOXY



DEVCON 2 PART EPOXY

25mL

Order Code: **AC-EPOXY**

SPECIFICATION

- Resealable syringe
- Mixing tray and stick included
- Extremely strong bonding for metal to metal

BUGLE BATTEN SCREW



BUGLE BATTEN SCREW 50MM LONG, HEX HEAD

Order Code: **FX-SS50**

SPECIFICATION

- Stainless steel 316
- 14 gauge x 50mm length with 11.5mm outer diameter head
- Ideal for timber fixing the wall plate

NEW!



NANORAIL MATT BLACK

POWDERCOATED STAINLESS STEEL 316

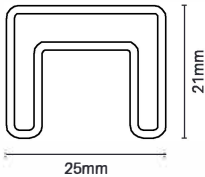

Available in



5800mm RHS Nanorail® handrail
25X21 MM - SS316L
Matt black finish
Order Code: **STG-R5800-2521-B**

- 5800mm long
- Slimline profile - caps over 12mm thick glass
- 1.2mm wall thickness
- 14x14mm glazing pocket - silicone onto glass or use with glazing rubber
- Low carbon SS316L

FULL RANGE OF FITTINGS ALSO AVAILABLE



Inline joiner
STG-2521-J-B



90° joiner
STG-2521-90J-B



Vertical joiner
STG-2521-VERTJ-B



Swivel vertical joiner
STG-2521-VJA-B



Swivel horizontal joiner
STG-2521-HJA-B



End cap
STG-2521-EC-B



Wall plate
STG-2521-WP-B



Extended wall plate
STG-2521-WPEXT-B

Summit Top Rail Range

Summit Nano Hand Rail (25.4mm) Series

NANOROUND 25.4MM DIAMETER HANDRAIL

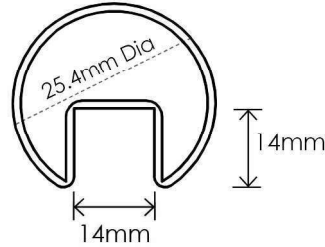

2900mm CHS HANDRAIL, 25.4mm Dia Polish Or Satin Finish

Order Code: **STG-C2900-25.4D-P** (polish finish)
STG-C2900-25.4D-S (satin finish)

5800mm CHS HANDRAIL, 25.4mm Dia Polish Or Satin Finish

Order Code: **STG-C5800-25.4D-P** (polish finish)
STG-C5800-25.4D-S (satin finish)

SPECIFICATION

- Available in 5800mm or 2900mm lengths; High Polish or Satin finish
- Slimline 25.4mm stylish profile – 'Nanoround' - caps over 12mm thick glass
- 1.5mm wall thickness
- 14 x 14mm glazing pocket: silicone onto glass or use in conjunction with glazing rubber
- Stainless Steel 316L - low carbon stainless

NANOROUND 25.4MM DIA JOINER

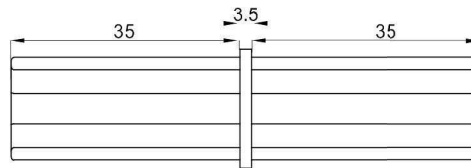

NANOROUND JOINER

316 STAINLESS STEEL

Satin Or Polish Finish

Order Code: **STG-25.4D-J-P** (polish finish)
STG-25.4D-J-S (satin finish)

SPECIFICATION

- In-line rail joiner
- Easy to use tap-in fitting: allows for increased speed of assembly
- Stainless Steel 316
- Epoxy glue, weld or drill/tap tube for joining strength

NANOROUND 25.4MM DIA, 90 DEGREE JOINER

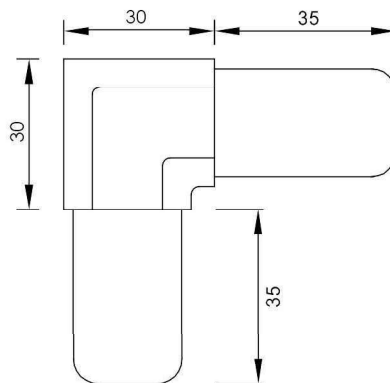

NANOROUND 90 DEGREE JOINER

316 STAINLESS STEEL

Satin Or Polish Finish

Order Code: **STG-25.4D-90J-P** (polish finish)
STG-25.4D-90J-S (satin finish)

SPECIFICATION

- 90 degree rail joiner
- Easy to use tap-in fitting: allows for increased speed of assembly
- Stainless Steel 316
- Epoxy glue, weld or drill/tap tube for joini

NOTE: ALL DRAWINGS ARE NOT TO SCALE

Summit Top Rail Range

NANOROUND 25.4MM DIA HORIZONTAL SWIVEL JOINER

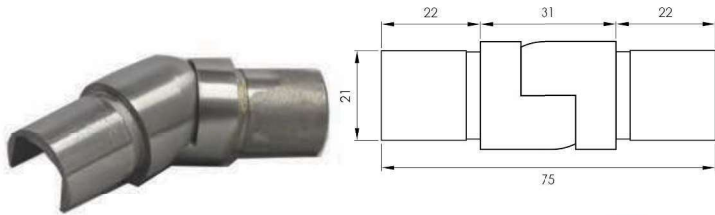

NANOROUND HORIZONTAL JOINER 316 STAINLESS STEEL Satin Or Polish Finish

Order Code: **STG-25.4D-HJA-P** (polish finish)
STG-25.4D-HJA-S (satin finish)

**VARIABLE
ANGLE**

SPECIFICATION

- Variable angle horizontal joiner
- From straight rail, achieve up to 45 degree left or right angle joining
- Epoxy glue, weld or drill/top tube for joining strength

NANOROUND 25.4MM DIA VERTICAL SWIVEL JOINER

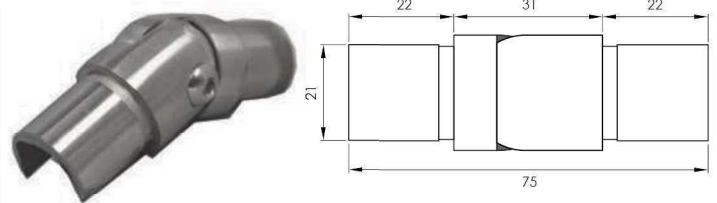

NANOROUND VERTICAL JOINER 316 STAINLESS STEEL Satin Or Polish Finish

Order Code: **STG-25.4D-VJA-P** (polish finish)
STG-25.4D-VJA-S (satin finish)

**VARIABLE
ANGLE**

SPECIFICATION

- Variable angle vertical joiner
- From straight rail, achieve up to 45 degrees upwards & downwards
- Ideal for staircase installation
- Epoxy glue, weld or drill/top tube for joining strength

NANOROUND 25.4MM DIA END CAP

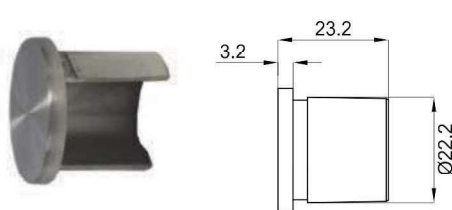

NOT TO SCALE

NANOROUND END CAP 316 STAINLESS STEEL Satin Or Polish Finish

Order Code: **STG-25.4D-EC-P** (polish finish)
STG-25.4D-EC-S (satin finish)

SPECIFICATION

- End cap; easy to use tap-in fitting
- Stainless Steel 316
- Epoxy glue, weld or drill/top tube for joining strength

**NEW
ALSO AVAILABLE
SLOTTED
END CAP**



**HIDDEN
FIXING**

STG-25.4D-SC-P/S
(polish or satin finish)

- Includes screw with bolt head
- Rail with slotted end cap simply drops over exposed screw head providing hidden fixing

NANOROUND 25.4MM DIA WALL PLATE



NOT TO SCALE

Offset grub screw hole for quick installation

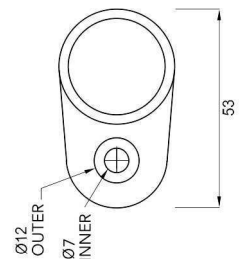

NANOROUND WALL PLATE 316 STAINLESS STEEL Satin Or Polish Finish

Order Code: **STG-25.4D-WP-P** (polish finish)
STG-25.4D-WP-S (satin finish)

SPECIFICATION

- Bracket can be affixed to wall/post
- 25.4mm tube fits into opening (female fit)
- Stainless Steel 316
- Epoxy glue, weld or drill/top tube for joining strength

NANOROUND GLAZING RUBBER



NANOROUND GLAZING RUBBER

Order Code: **STG-SP1109-30**

SPECIFICATION

- Assists in the installation of NANOROUND to 12mm glass: suggested to use in conjunction with silicone
- Thin U profile RUBBER - 30 Metre Roll - provides for a tight fit
- Used also as a barrier between glass edge and stainless steel rail

BOSTIK V60 GLAZING SILICONE



BOSTIK V60 TRANSLUCENT GLAZING SILICONE 300G

Order Code: **FB-V60**

SPECIFICATION

- Architectural grade high performance glazing silicone
- Neutral cure sealant specially formulated; skins quickly & provides long term performance
- Excellent adhesion & flexibility
- Seals water tight - UV & weather resistant

DEVCON 2 PART EPOXY



DEVCON 2 PART EPOXY 25mL

Order Code: **DEV-EPOXY**

SPECIFICATION

- Resealable syringe
- Mixing tray and stick included
- Extremely strong bonding for metal to metal

BUGLE BATTEN SCREW



BUGLE BATTEN SCREW 50MM LONG, HEX HEAD

Order Code: **CSK-050**

SPECIFICATION

- Stainless steel 316
- 14 gauge x 50mm length with 11.5mm outer diameter head
- Ideal for timber fixing the wall plate

Summit Top Rail Range

Summit Slimline Round Hand Rail (38mm) Range

SUMMIT CHS 38MM DIA HANDRAIL

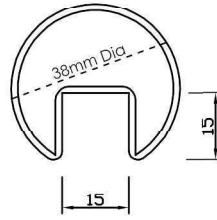

2900mm CHS ROUND HANDRAIL, 38mm DIA Polish Or Satin Finish

Order Code: **STG-C2900-38D-P** (polish finish)
STG-C2900-38D-S (satin finish)

5800mm CHS ROUND HANDRAIL, 38mm DIA Polish Or Satin Finish

Order Code: **STG-C5800-38D-P** (polish finish)
STG-C5800-38D-S (satin finish)

SPECIFICATION

- Available in 5800 or 2900mm lengths; High Polish or Satin finish
- 1.5mm wall thickness
- 15 x 15mm glazing pocket: Silicone onto glass or use in conjunction with glazing rubber
- Stainless Steel 316L - low carbon stainless

SUMMIT CHS 38MM DIAMETER JOINER

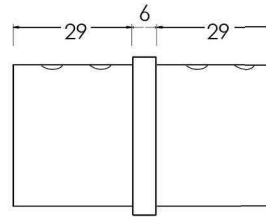

SUMMIT 38mm DIA JOINER

316 STAINLESS STEEL

Satin Or Polish Finish

Order Code: **STG-38D-J-P** (polish finish)
STG-38D-J-S (satin finish)

SPECIFICATION

- In-line rail joiner
- Easy to use tap-in fitting: allows for increased speed of assembly
- Stainless Steel 316
- Epoxy glue, weld or drill/tap tube for joining strength

SUMMIT CHS 38MM DIAMETER 90 DEGREE JOINER

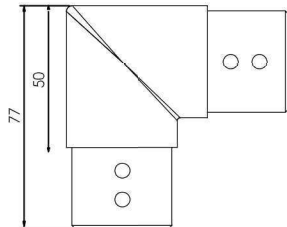

SUMMIT 38mm DIA 90° JOINER

316 STAINLESS STEEL

Satin Or Polish Finish

Order Code: **STG-38D-90J-P** (polish finish)
STG-38D-90J-S (satin finish)

SPECIFICATION

- 90 degree corner joiner; easy to use tap-in fitting
- Stainless Steel 316
- Epoxy glue, weld or drill/tap tube for joining strength

SUMMIT CHS 38MM DIAMETER RADIUS CORNER JOINER

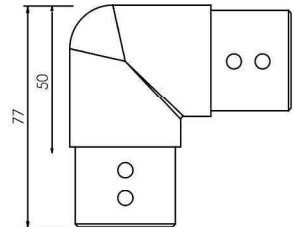

SUMMIT 38mm DIA RADIUS CORNER JOINER

316 STAINLESS STEEL

Satin Or Polish Finish

Order Code: **STG-38D-VJ-P** (polish finish)
STG-38D-VJ-S (satin finish)

SPECIFICATION

- 90 degree RADIUS corner joiner; easy to use tap-in fitting
- Stainless Steel 316
- Epoxy glue, weld or drill/tap tube for joining strength

NOTE: ALL DRAWINGS ARE NOT TO SCALE

Summit Top Rail Range

SUMMIT CHS 38MM DIAMETER END CAP

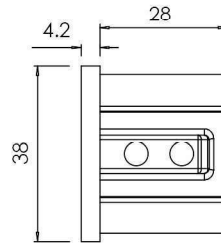
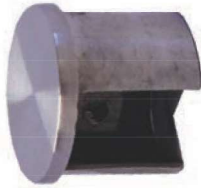

SUMMIT 38mm DIA END CAP

316 STAINLESS STEEL

Satin Or Polish Finish

Order Code: **STG-38D-EC-P** (polish finish)
STG-38D-EC-S (satin finish)

SPECIFICATION

- End cap; easy to use tap-in fitting
- Stainless Steel 316
- Epoxy glue, weld or drill/tap tube for joining strength

SLIMLINE FLANGE SUMMIT 38MM DIA WALL PLATE

EXTENDED FLANGE SUMMIT 38MM DIA WALL PLATE

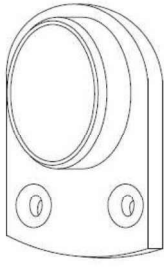

Front Elevation



Consider CSK-050 for timber fixing

Bugle Batten Screw
50mm long (hex drive head)

- Stainless steel 316
- 14 gauge x 50mm length with 11.5mm outer diameter head
- Ideal for fixing wall bracket to timber

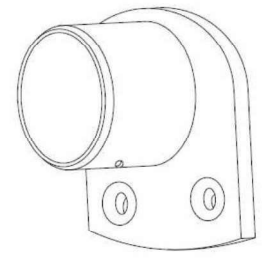

Front Elevation

38mm DIA SLIMLINE WALL PLATE

316 STAINLESS STEEL

Satin Or Polish Finish

Order Code: **FB-38D-WP-P** (polish finish)
FB-38D-WP-S (satin finish)

SPECIFICATION

- Slimline bracket can be affixed to wall/post
- 38mm tube fits into 10mm deep opening (female fit)
- Stainless Steel 316
- Epoxy glue, weld or drill/tap tube for joining strength

38mm DIA EXTENDED WALL PLATE

316 STAINLESS STEEL

Satin Or Polish Finish

Order Code: **FB-38D-WP25-P** (polish finish)
FB-38D-WP25-S (satin finish)

SPECIFICATION

- EXTENDED mouth bracket can be affixed to wall/post
- 38mm tube fits into opening 25mm deep (female fit)
- Stainless Steel 316
- Epoxy glue, weld or drill/tap tube for joining strength

SUMMIT GLAZING RUBBER

BOSTIK V60 GLAZING SILICONE



STG-SP1097



STG-SP1103

SUMMIT GLAZING RUBBER

Order Code: **STG-SP1097** (for polish handrail)
STG-SP1103 (for satin handrail)

SPECIFICATION

- Assists in the installation of 38mm diameter & 54 x 30 rectangular slotted handrail: suggested to use in conjunction with silicone
- Thin U profile RUBBER - 75 metre roll - provides for a tight fit
- Used also as a barrier between glass edge and stainless steel rail
- Suits 12mm thick glass only



BOSTIK V60 TRANSLUCENT GLAZING SILICONE 300G

Order Code: **FB-V60**

SPECIFICATION

- Architectural grade high performance glazing silicone
- Neutral cure sealant specially formulated; skins quickly & provides long term performance
- Excellent adhesion & flexibility
- Seals water tight - UV & weather resistant

DEVCON 2 PART EPOXY



DEVCON 2 PART EPOXY 25mL

Order Code: **DEV-EPOXY**

SPECIFICATION

- Resealable syringe
- Mixing tray and stick included
- Extremely strong bonding for metal to metal

NOTE: ALL DRAWINGS ARE NOT TO SCALE

Summit Top Rail Range

Summit Grip rail (40x30mm) Series

GRIPRAIL® 40 X 30MM HANDRAIL

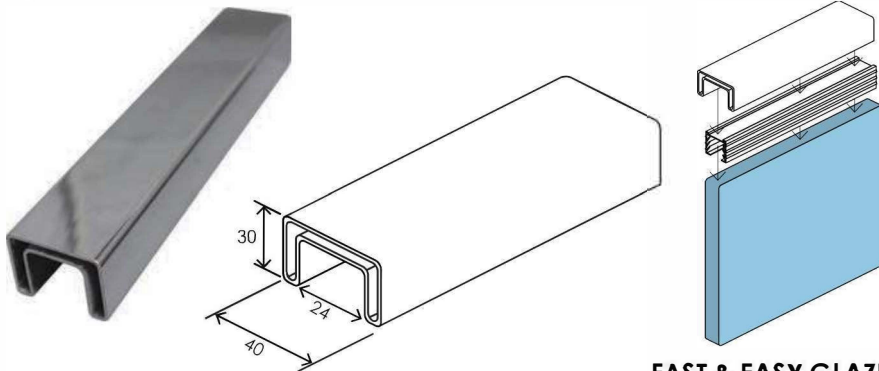

SPECIFICATION

- Available in 5800 or 2900mm lengths; High Polish or Satin finish
- Stylish slimline 40mm wide x 30mm high profile
- 1.5mm wall thickness
- 24 x 24mm glazing pocket: special glazing rubber holds fast to glass & rail
- Stainless Steel 316L - low carbon stainless

FAST & EASY GLAZING

5800mm GRIPRAIL® HANDRAIL, 40 x 30mm Polish Or Satin Finish

Order Code: **STG-R5800-4030-P** (polish finish)

Order Code: **STG-R5800-4030-S** (satin finish)

GRIPRAIL® RUBBER

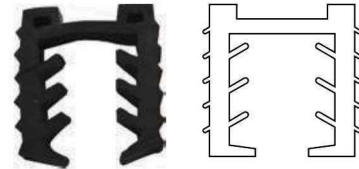

40 x 30mm GRIPRAIL® RUBBER

Order Code: **STG-4030-GR**

SPECIFICATION

- 6 metre lengths
- Special interior ribs secure glass to rail
- Fast and easy glazing : provides a perfect finish
- Also used as a barrier between glass edge and stainless steel rail
- Suits 12mm thick glass only

GRIPRAIL® JOINER

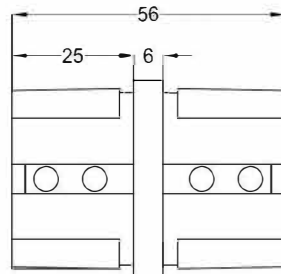

40 x 30mm GRIPRAIL® JOINER Polish Or Satin Finish

Order Code: **STG-4030-J-P** (polish finish)

Order Code: **STG-4030-J-S** (satin finish)

SPECIFICATION

- In-line rail joiner
- Easy to use tap-in fitting; allows for increased speed of assembly
- Stainless Steel 316
- Epoxy glue, weld or drill/tap tube for joining strength

GRIPRAIL® 90 DEGREE JOINER

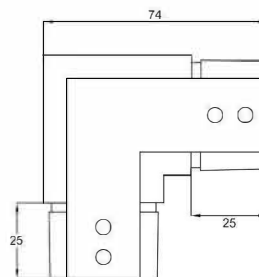

40 x 30mm GRIPRAIL® 90° JOINER Polish Or Satin Finish

Order Code: **STG-4030-90J-P** (polish finish)

Order Code: **STG-4030-90J-S** (satin finish)

SPECIFICATION

- 90 degree corner joiner; easy to use tap-in fitting
- Stainless Steel 316
- Epoxy glue, weld or drill/tap tube for joining strength

STAINLESS STEEL HANDRAIL

Summit Top Rail Range

GRIPRAIL® SWIVEL HORIZONTAL JOINER



VARIABLE ANGLE

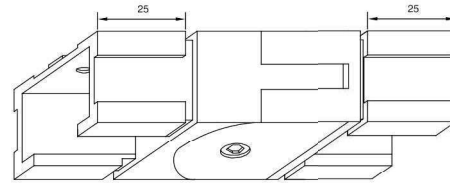

40 x 30mm GRIPRAIL® HORIZONTAL JOINER Polish Or Satin Finish

Order Code: **STG-4030-HJA-P** (polish finish)
STG-4030-HJA-S (satin finish)

SPECIFICATION

- Variable angle horizontal joiner ; easy to use tap-in fitting
- From straight rail, achieve up to 45 degrees angle joining
- Stainless Steel 316
- Epoxy glue, weld or drill/tap tube for joining strength

GRIPRAIL® SWIVEL VERTICAL JOINER



VARIABLE ANGLE

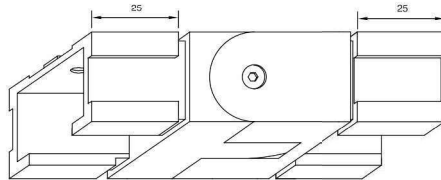

40 x 30mm GRIPRAIL® VERTICAL JOINER Polish Or Satin Finish

Order Code: **STG-4030-VJA-P** (polish finish)
STG-4030-VJA-S (satin finish)

SPECIFICATION

- Variable angle vertical joiner; easy to use tap-in fitting
- From straight rail, achieve up to 45 degrees upwards & downwards
- Stainless Steel 316
- Epoxy glue, weld or drill/tap tube for joining strength

GRIPRAIL® END CAP

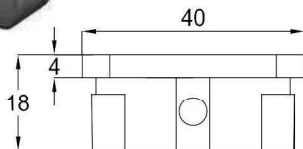

40 x 30mm GRIPRAIL® END CAP Polish Or Satin Finish

Order Code: **STG-4030-EC-P** (polish finish)
STG-4030-EC-S (satin finish)

SPECIFICATION

- End cap; easy to use tap-in fitting
- Stainless Steel 316
- Epoxy glue, weld or drill/tap tube for joining strength

**NEW ALSO AVAILABLE
SLOTTED
END CAP**



HIDDEN FIXING

STG-4030-SC-P/S
(polish or satin finish)
• Includes screw with bolt head
• Rail with slotted end cap simply drops over exposed screw head providing hidden fixing

GRIPRAIL® WALL PLATE

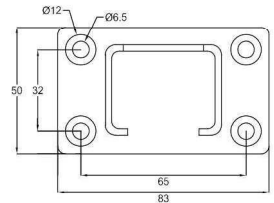

40 X 30mm GRIPRAIL® WALL PLATE Polish Or Satin Finish

Order Code: **STG-4030-WP-P** (polish finish)
STG-4030-WP-S (satin finish)

SPECIFICATION

- Bracket can be affixed to wall/post
- 40 x 30mm rail fits into 30mm deep opening (female fit)
- Stainless Steel 316
- Epoxy glue, weld or drill/tap tube for joining strength

DEVCON 2 PART EPOXY



DEVCON 2 PART EPOXY 25mL

Order Code: **DEV-EPOXY**

SPECIFICATION

- Resealable syringe
- Mixing tray and stick included
- Extremely strong bonding for metal to metal

BUGLE BATTEN SCREW

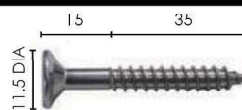

BUGLE BATTEN SCREW 50MM LONG, HEX HEAD

Order Code: **CSK-050**

SPECIFICATION

- Stainless steel 316
- 14 gauge x 50mm length with 11.5mm outer diameter head
- Ideal for timber fixing the wall plate

Summit Top Rail Range

Summit RHS Handrail (54 x 30mm) Range

SUMMIT RHS 54 X 30MM HANDRAIL

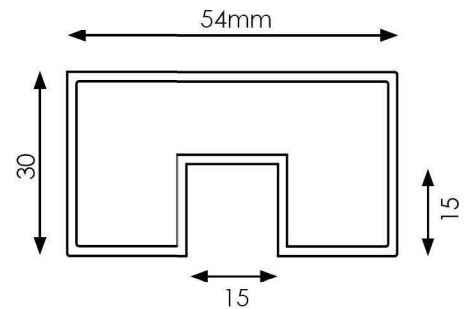

2900mm RHS HANDRAIL 54 x 30mm Polish Or Satin Finish

Order Code: **STG-R2900-5430-P** (polish finish)
STG-R2900-5430-S (satin finish)

5800mm RHS HANDRAIL, 54 x 30mm Polish Or Satin Finish

Order Code: **STG-R5800-5430-P** (polish finish)
STG-R5800-5430-S (satin finish)

SPECIFICATION

- Available in 5800 or 2900mm lengths; High Polish or Satin finish
- Robust 54mm wide x 30mm high rail
- 1.5mm wall thickness
- 15 x 15mm glazing pocket: silicone onto glass or use in conjunction with glazing rubber
- Stainless Steel 316L - low carbon stainless

SUMMIT 54 X 30MM JOINER

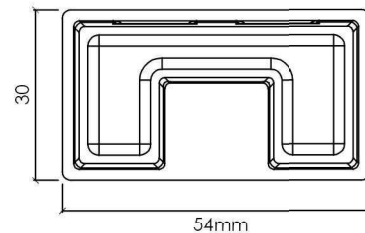

SUMMIT 54 x 30mm JOINER

316 STAINLESS STEEL

Satin Or Polish Finish

Order Code: **STG-5430-J-P** (polish finish)
STG-5430-J-S (satin finish)

SPECIFICATION

- In-line rail joiner
- Easy to use tap-in fitting: allows for increased speed of assembly
- Stainless Steel 316
- Epoxy glue, weld or drill/tap tube for joining strength

SUMMIT 54 X 30MM 90 DEGREE JOINER

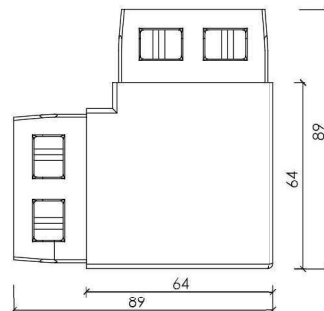

SUMMIT 54 x 30mm 90 DEGREE JOINER

316 STAINLESS STEEL

Satin Or Polish Finish

Order Code: **STG-5430-90J-P** (polish finish)
STG-5430-90J-S (satin finish)

SPECIFICATION

- 90 degree corner joiner ; easy to use tap-in fitting
- Stainless Steel 316
- Epoxy glue, weld or drill/tap tube for joining strength

NOTE: ALL DRAWINGS ARE NOT TO SCALE

Summit Top Rail Range

SUMMIT 54 X 30MM END CAP

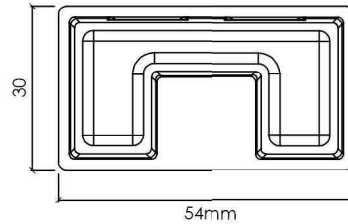

SUMMIT 54 x 30mm END CAP

316 STAINLESS STEEL

Satin Or Polish Finish

Order Code: **STG-5430-EC-P** (polish finish)
STG-5430-EC-S (satin finish)

SPECIFICATION

- End cap; easy to use tap-in fitting
- Stainless Steel 316
- Epoxy glue, weld or drill/tap tube for joining strength

SUMMIT 54 X 30MM WALL PLATE

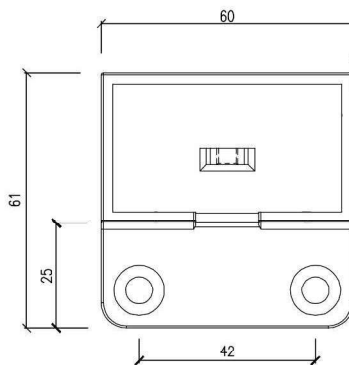
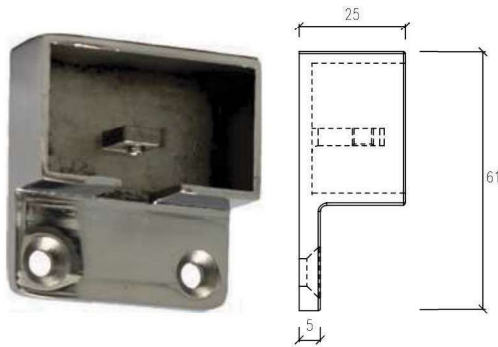

SUMMIT 54 x 30mm WALL PLATE

316 STAINLESS STEEL

Satin Or Polish Finish

Order Code: **STG-5430-WP-P** (polish finish)
STG-5430-WP-S (satin finish)

SPECIFICATION

- Bracket can be affixed to wall/post
- 54 x 30mm rail fits into opening (female fit)
- Stainless Steel 316
- Epoxy glue, weld or drill/tap tube for joining strength

SUMMIT GLAZING RUBBER



STG-SP1097

STG-SP1103

SUMMIT GLAZING RUBBER

Order Code: **STG-SP1097** (for polish handrail)
STG-SP1103 (for satin handrail)

SPECIFICATION

- Assists in the installation of 38mm diameter & 54 x 30 rectangular slotted handrail; suggested to use in conjunction with silicone
- Thin U profile RUBBER - 75 metre roll - provides for a tight fit
- Used also as a barrier between glass edge and stainless steel rail
- Suits 12mm thick glass only

BOSTIK V60 GLAZING SILICONE



BOSTIK V60 TRANSLUCENT GLAZING SILICONE 300G

Order Code: **FB-V60**

SPECIFICATION

- Architectural grade high performance glazing sil
- Neutral cure sealant specially formulated; skins quickly & provides long term performance
- Excellent adhesion & flexibility
- Seals water tight - UV & weather resistant

DEVCON 2 PART EPOXY



DEVCON 2 PART EPOXY 25mL

Order Code: **DEV-EPOXY**

SPECIFICATION

- Resealable syringe
- Mixing tray and stick included
- Extremely strong bonding for metal to metal

NOTE: ALL DRAWINGS ARE NOT TO SCALE

Summit Top Rail Range

Summit Round Hand rail (50.8mm) Series

SLOT 50 - ROUND SLOTTED 50.8MM DIA HANDRAIL

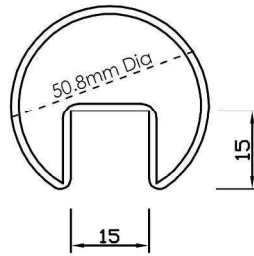

5800mm CHS ROUND HANDRAIL, 50.8mm DIA Polish Finish

Order Code: **SLOT50-5000-1W-P** (polish finish)

SPECIFICATION

- Available in 5800 length; High Polish finish
- 1.5mm wall thickness
- 15 x 15mm glazing pocket: Silicone onto glass or use in conjunction with glazing rubber
- Stainless Steel 316L - Low carbon stainless

SLOT 50 - 50.8MM DIAMETER INLINE JOINER



SLOT 50 INLINE JOINER Polish Finish

Order Code: **SLOT50-J-P** (polish finish)

SPECIFICATION

- Stainless Steel 316
- Epoxy glue, weld or drill/tap tube for joining strength

SLOT 50 - 50.8MM DIAMETER 90 DEGREE JOINER



SLOT 50 90 DEGREE JOINER Polish Finish

Order Code: **SLOT50-J90-P** (polish finish)

SPECIFICATION

- Stainless Steel 316
- Epoxy glue, weld or drill/tap tube for joining strength

SLOT 50 - 50.8MM DIAMETER FLAT END CAP



SLOT 50 FLAT END CAP Polish Finish

Order Code: **SLOT50-EC-P** (polish finish)

SPECIFICATION

- Stainless Steel 316
- Epoxy glue, weld or drill/tap tube for joining strength

EXTENDED FLANGE SLOT 50 - 50.8MM DIA. WALL PLATE



EXTENDED FLANGE WALL PLATE Polish Finish

Order Code: **FB-50D-WP25-P** (polish finish)

SPECIFICATION

- EXTENDED mouth bracket can be affixed to wall/post
- 50.8mm tube fits into opening 25mm deep (female fit)
- Stainless Steel 316
- Epoxy glue, weld or drill/tap tube for joining strength

STAINLESS STEEL HANDRAIL

FOR GLAZING RUBBER, EPOXY & SILICONE REFER TO PAGE 12

NOTE: ALL DRAWINGS ARE NOT TO SCALE

SOLO Side Rail Range

Solo 50x10mm Handrail Series

SOLO 50 X 10MM HANDRAIL

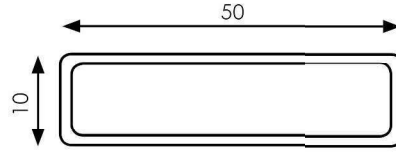

2900mm RHS HANDRAIL, 50 x 10mm Polish Or Satin Finish

Order Code: [SOLO-R2900-5010-P](#) (polish finish)
[SOLO-R2900-5010-S](#) (satin finish)

5800mm RHS HANDRAIL, 50 x 10mm Polish Or Satin Finish

Order Code: [SOLO-R5800-5010-P](#) (polish finish)
[SOLO-R5800-5010-S](#) (satin finish)

SPECIFICATION

- Available in 5800 or 2900mm lengths ; High Polish or Satin finish
- Slimline modern profile
- 1.5mm wall thickness
- Stainless Steel 316L - low carbon stainless

SOLO 50 X 10MM RAIL CONNECTOR



30mm DIA

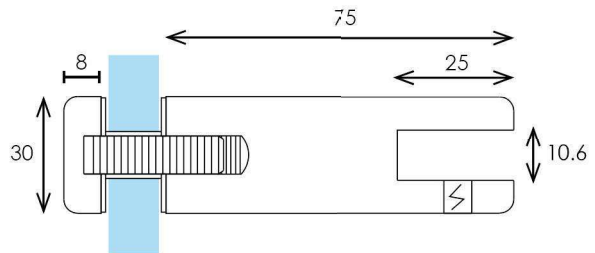
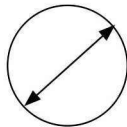

SOLO 50 x 10mm, RAIL CONNECTOR Polish Or Satin Finish

Order Code: [SOLO-5010-RC-P](#) (polish finish)
[SOLO-5010-RC-S](#) (satin finish)

SPECIFICATION

- Standoff rail connector: neat finish slot to suit 50x10mm handrail
- Stainless Steel 316
- Suits 12mm thick glass with 16 to 20mm drilled top handrail holes

SOLO 50 X 10MM JOINER

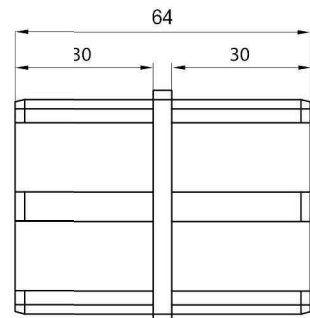
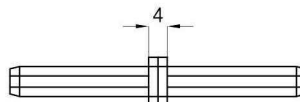

SOLO 50 x 10mm, JOINER Polish Or Satin Finish

Order Code: [SOLO-5010-J-P](#) (polish finish)
[SOLO-5010-J-S](#) (satin finish)

SPECIFICATION

- In-line rail joiner; easy to use tap-in fitting
- Stainless Steel 316
- Epoxy glue, weld or drill/tap tube for joining strength

SOLO Side Rail Range

SOLO 50 X 10MM 90 DEG JOINER

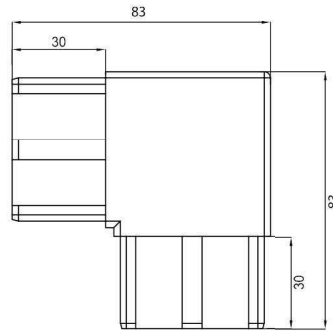

SOLO 50 x 10mm, 90 DEGREE JOINER

Polish Or Satin Finish

Order Code: [SOLO-5010-90J-P](#) (polish finish)
[SOLO-5010-90J-S](#) (satin finish)

SPECIFICATION

- 90 degree corner joiner; easy to use tap-in fitting
- Stainless Steel 316
- Epoxy glue, weld or drill/tap tube for joining strength

SOLO 50 X 10MM VERTICAL JOINER

VARIABLE ANGLE

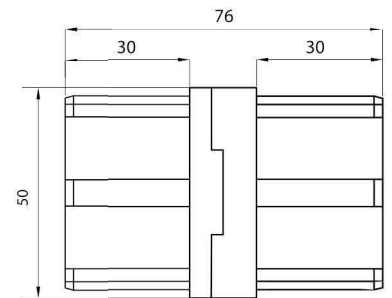
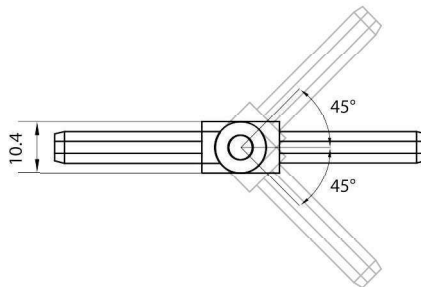

SOLO 50 x 10mm, VERTICAL JOINER

Polish Or Satin Finish

Order Code: [SOLO-5010-VJA-P](#) (polish finish)
[SOLO-5010-VJA-S](#) (satin finish)

SPECIFICATION

- Variable angle vertical joiner : ideal for staircases. Upwards & downwards to 45 degrees
- Stainless Steel 316
- Epoxy glue, weld or drill/tap tube for joining strength

SOLO 50 X 10MM HORIZONTAL SWIVEL JOINER

VARIABLE ANGLE

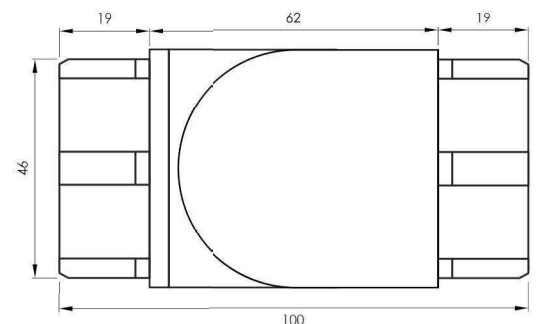
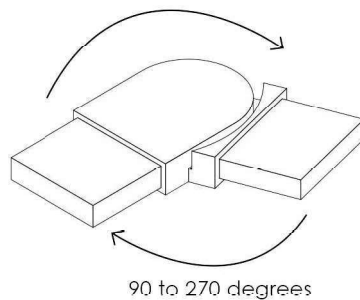

SOLO 50 x 10mm, HORIZONTAL SWIVEL JOINER

Polish Or Satin Finish

Order Code: [SOLO-5010-HJA-P](#) (polish finish)
[SOLO-5010-HJA-S](#) (satin finish)

SPECIFICATION

- Variable angle horizontal joiner: tap in fitting
- From straight rail, achieve up to 90 degrees left or right
- Stainless Steel 316
- Epoxy glue, weld or drill/tap tube for joining strength

SOLO Side Rail Range

SOLO 50 X 10MM END CAP

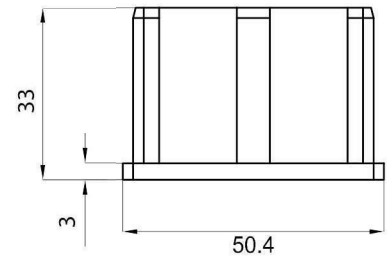
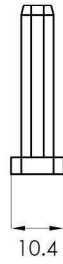

SOLO 50 x 10mm, END CAP

Polish Or Satin Finish

Order Code: [SOLO-5010-EC-P](#) (polish finish)
[SOLO-5010-EC-S](#) (satin finish)

SPECIFICATION

- End cap; easy to use tap-in fitting
- Stainless Steel 316
- Epoxy glue, weld or drill/tap tube for joining strength

SOLO 50 X 10MM WALL PLATE

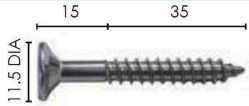

Consider [CSK-050](#) for timber fixing

Bugle Batten Screw

50mm long (hex drive head)

- Stainless steel 316
- 14 gauge x 50mm length with 11.5mm outer diameter head
- Ideal for fixing wall bracket to timber

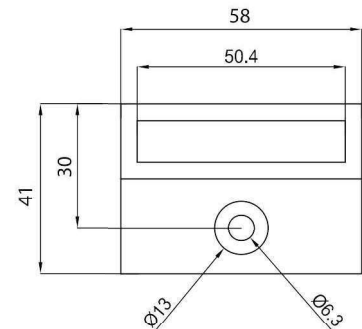
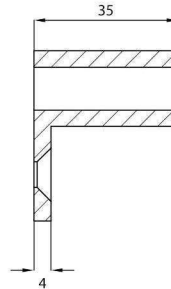

SOLO 50 x 10mm, WALL PLATE

Polish Or Satin Finish

Order Code: [SOLO-5010-WP-P](#) (polish finish)
[SOLO-5010-WP-S](#) (satin finish)

SPECIFICATION

- Bracket can be affixed to wall/post
- 50 x 10mm tube fits into opening (female fit)
- Stainless Steel 316
- Epoxy glue, weld or drill/tap tube for joining strength
- ADDED FEATURE: Internal grub screw holds handrail in position

SOLO 50 X 10MM EXTENDED WALL PLATE



slide out cover to hide fixings

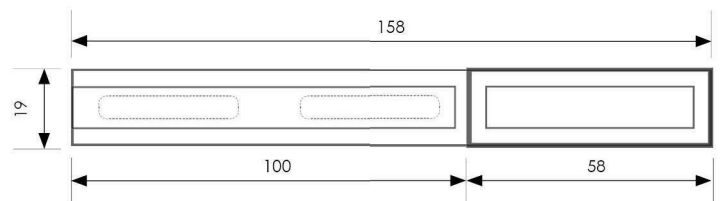

SOLO 50 x 10mm, EXTENDED WALL PLATE

Polish Or Satin Finish

Order Code: [SOLO-5010-WPEXT-P](#) (polish finish)
[SOLO-5010-WPEXT-S](#) (satin finish)

SPECIFICATION

- Extended wall plate can be affixed to wall or post
- Ideal where handrail is offset from a wall or post
- Slide in/out cover hides fixings
- Each slotted hole is 35mm wide & 6.5mm high
- 50 x 10mm tube fits into opening (female fit)
- Internal grub screw holds handrail in position

DEVCON 2 PART EPOXY



DEVCON 2 PART EPOXY

25mL

Order Code: [DEV-EPOXY](#)

SPECIFICATION

- Resealable syringe
- Mixing tray and stick included
- Extremely strong bonding for metal to metal

NOTE: ALL DRAWINGS ARE NOT TO SCALE

NEW!

SOLO 50X10 MATT BLACK

POWDERCOATED STAINLESS STEEL 316

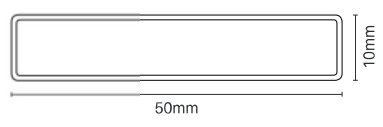
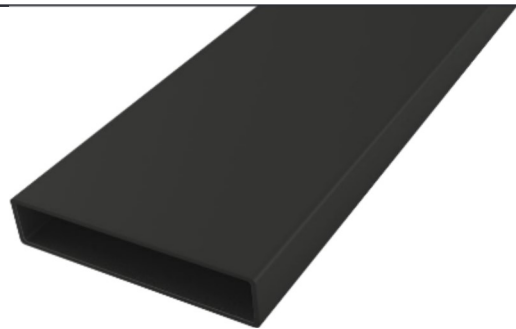

5800mm RHS SOLO handrail
50X10MM - SS316L
Matt black finish
Order Code: SOLO-R5800-5010-B

- 5800mm long
- Slimline profile
- 1.5mm wall thickness
- Low carbon SS316L
- Akzo Nobel textured matt black powder coat

FULL RANGE OF FITTINGS ALSO AVAILABLE

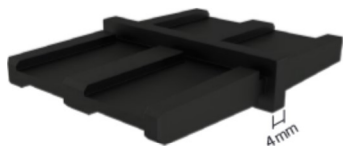

Inline joiner
SOLO-5010-J-B

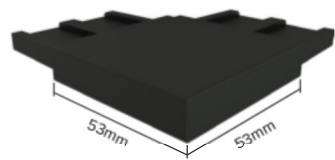

90° joiner
SOLO-5010-90J-B

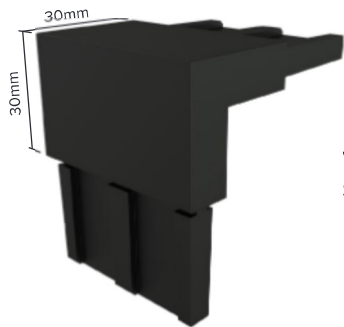

Vertical joiner
SOLO-5010-VJ-B

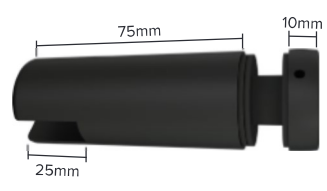

Rail connector
SOLO-5010-RC-B

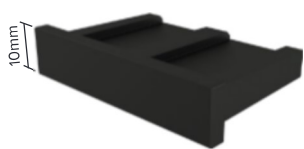

End cap
SOLO-5010-EC-B

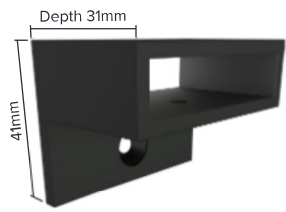

Wall plate
SOLO-5010-WP-B

EURO Offset Handrail Range

Euro Offset 30mm Diametre Handrail

30MM DIA EURO OFFSET HANDRAIL

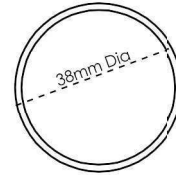

2900mm CHS ROUND HANDRAIL, 38mm DIA. Polish Or Satin Finish

Order Code: [EOS-C2900-38D-P](#) (polish finish)
[EOS-C2900-38D-S](#) (satin finish)

5800mm CHS ROUND HANDRAIL, 38mm DIA. Polish Or Satin Finish

Order Code: [EOS-C5800-38D-P](#) (polish finish)
[EOS-C5800-38D-S](#) (satin finish)

SPECIFICATION

- Available in 5800 or 2900mm lengths; High Polish or Satin finish
- 1.5mm wall thickness
- Stainless Steel 316L - low carbon stainless

EURO OFFSET 38MM DIAMETER JOINER

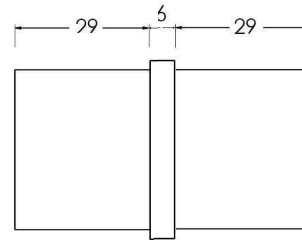
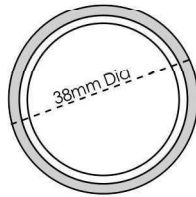

38mm DIA. JOINER Polish Or Satin Finish

Order Code: [EOS-38D-J-P](#) (polish finish)
[EOS-38D-J-S](#) (satin finish)

SPECIFICATION

- In-line rail joiner
- Easy to use tap-in fitting: allows for increased speed of assembly
- Stainless Steel 316
- Epoxy glue, weld or drill/tap tube for joining strength

EURO OFFSET 38MM DIAMETER 90 DEGREE JOINER

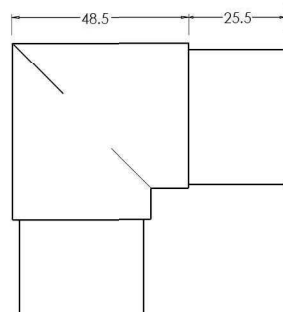

38mm DIA. 90 DEGREE JOINER Polish Or Satin Finish

Order Code: [EOS-38D-90J-P](#) (polish finish)
[EOS-38D-90J-S](#) (satin finish)

SPECIFICATION

- 90 degree corner joiner; easy to use tap-in fitting
- Stainless Steel 316
- Epoxy glue, weld or drill/tap tube for joining strength

EURO OFFSET 38MM DIAMETER RADIUS JOINER

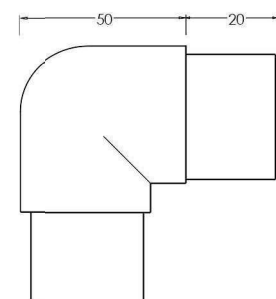

* ALSO SUITABLE AS A VERTICAL JOINER

38MM DIA. RADIUS JOINER Polish Or Satin Finish

Order Code: [EOS-38D-VJ-P](#) (polish finish)
[EOS-38D-VJ-S](#) (satin finish)

SPECIFICATION

- 90 degree radius corner joiner ; easy to use tap-in fitting
- Stainless Steel 316
- Epoxy glue, weld or drill/tap tube for joining strength

EURO Offset Handrail Range

EURO OFFSET 38MM DIAMETER SWIVEL JOINER

**VARIABLE
ANGLE**

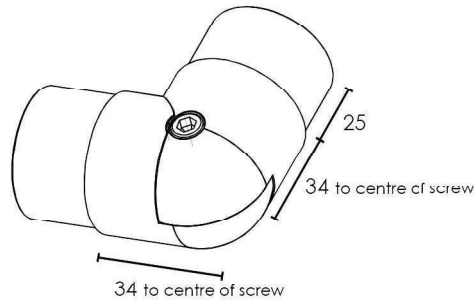

38MM DIA. SWIVEL JOINER

Polish Or Satin Finish

Order Code: **EOS-38D-JS-P** (polish finish)
EOS-38D-JS-S (satin finish)

SPECIFICATION

- Adjustable 'swivel' joiner, angle from 90 to 180 degrees
- Stainless Steel 316
- Epoxy glue, weld or drill/tap tube for joining strength

EURO OFFSET DOMED END CAP

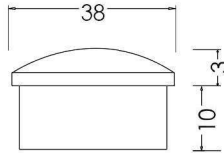

EURO 38mm DIA. DOMED END CAP

316 STAINLESS STEEL

Polish Or Satin Finish

Order Code: **EOS-38D-DEC-P** (polish finish)
EOS-38D-DEC-S (satin finish)

SPECIFICATION

- Domed end cap ; easy to use tap-in fitting
- Stainless Steel 316
- Epoxy glue, weld or drill/tap tube for joining strength

EURO OFFSET FLAT END CAP

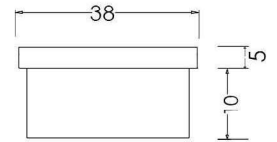

EURO 38mm DIA. FLAT END CAP

316 STAINLESS STEEL

Polish Or Satin Finish

Order Code: **EOS-38D-FEC-P** (polish finish)
EOS-38D-FEC-S (satin finish)

SPECIFICATION

- Flat end cap
- Stainless Steel 316
- Epoxy glue, weld or drill/tap tube for joining strength

SLIMLINE FLANGE 38MM DIA WALL PLATE

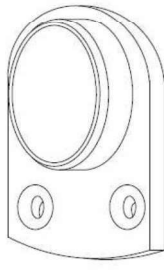

Front Elevation



Consider CSK-050 for timber fixing

Bugle Batten Screw
50mm long (hex drive head)

- Stainless steel 316
- 14 gauge x 50mm length with 11.5mm outer diameter head

38mm DIA. SLIMLINE WALL PLATE

316 STAINLESS STEEL

Polish Or Satin Finish

Order Code: **FB-38D-WP-P** (polish finish)
FB-38D-WP-S (satin finish)

SPECIFICATION

- Slimline bracket can be affixed to wall/post
- 38mm tube fits into 10mm deep opening (female fit)
- Stainless Steel 316
- Epoxy glue, weld or drill/tap tube for joining strength

EXTENDED FLANGE 38MM DIA WALL PLATE

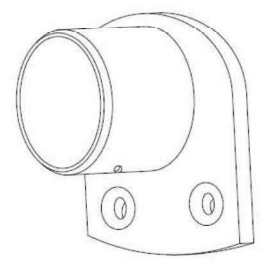

Front Elevation

38mm DIA. EXTENDED WALL PLATE

316 STAINLESS STEEL

Polish Or Satin Finish

Order Code: **FB-38D-WP25-P** (polish finish)
FB-38D-WP25-S (satin finish)

SPECIFICATION

- EXTENDED mouth bracket can be affixed to wall/post
- 38mm tube fits into opening 25mm deep (female fit)
- Stainless Steel 316
- Epoxy glue, weld or drill/tap tube for joining strength

NOTE: ALL DRAWINGS ARE NOT TO SCALE

EURO Offset Handrail Range

Euro Offset 50x25 Handrail

50 X 25MM EURO OFFSET HANDRAIL

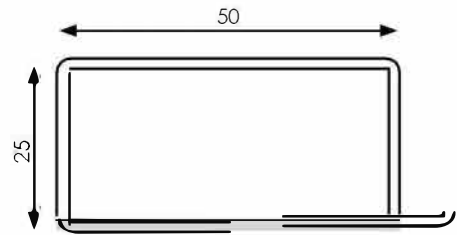

2900mm RHS HANDRAIL, 50 x 25MM Polish Or Satin Finish

Order Code: [EOS-R2900-5025-P](#) (polish finish)
[EOS-R2900-5025-S](#) (satin finish)

5800mm RHS HANDRAIL, 50 x 25MM Polish Or Satin Finish

Order Code: [EOS-R5800-5025-P](#) (polish finish)
[EOS-R5800-5025-S](#) (satin finish)

SPECIFICATION

- Available in 5800 or 2900mm lengths; High Polish or Satin finish
- 1.5mm wall thickness
- Stainless Steel 316L - low carbon stainless

50 X 25MM EURO OFFSET JOINER

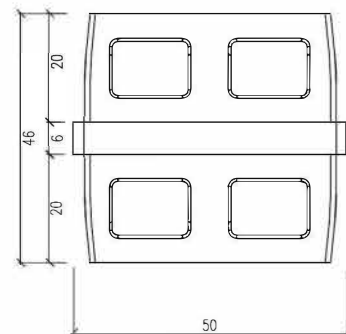

EURO 50 x 25mm JOINER Polish Or Satin Finish

Order Code: [EOS-5025-J-P](#) (polish finish)
[EOS-5025-J-S](#) (satin finish)

SPECIFICATION

- In-line rail joiner
- Easy to use tap-in fitting: allows for increased speed of assembly
- Stainless Steel 316
- Epoxy glue, weld or drill/tap tube for joining strength

50 X 25MM EURO OFFSET 90 DEGREE JOINER

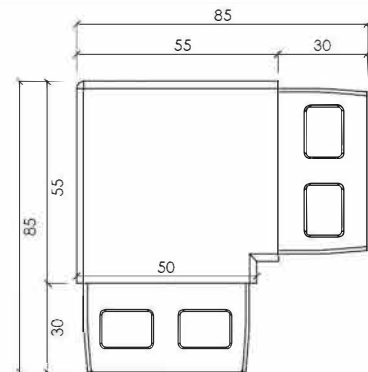

EURO 50 x 25mm, 90 DEGREE JOINER Polish Or Satin Finish

Order Code: [EOS-5025-90J-P](#) (polish finish)
[EOS-5025-90J-S](#) (satin finish)

SPECIFICATION

- 90 degree corner joiner; easy to use tap-in fitting
- Stainless Steel 316
- Epoxy glue, weld or drill/tap tube for joining strength

NOTE: ALL DRAWINGS ARE NOT TO SCALE

STAINLESS STEEL HANDRAIL

EURO Offset Handrail Range

50 X 25MM EURO OFFSET END CAP

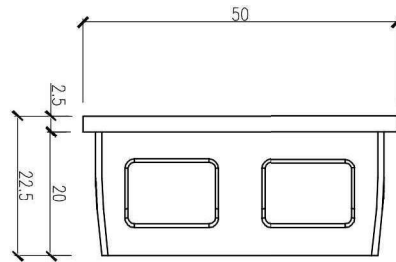

EURO 50 x 25mm END CAP Polish Or Satin Finish

Order Code: [EOS-5025-EC-P](#) (polish finish)
[EOS-5025-EC-S](#) (satin finish)

SPECIFICATION

- End cap; easy to use tap-in fitting
- Stainless Steel 316
- Epoxy glue, weld or drill/tap tube for joining strength

50 X 25MM EURO WALL PLATE

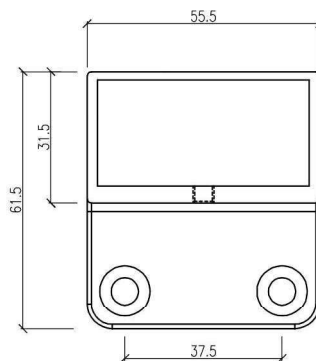

EURO 50 x 25mm WALL PLATE Polish Or Satin Finish

Order Code: [EOS-5025-WP-P](#) (polish finish)
[EOS-5025-WP-S](#) (satin finish)

SPECIFICATION

- Bracket can be affixed to wall/post
- 50 x 25mm tube fits into 10mm deep opening (female fit)
- Stainless Steel 316
- Epoxy glue, weld or drill/tap tube for joining strength

DEVCON 2 PART EPOXY



DEVCON 2 PART EPOXY 25mL

Order Code: [DEV-EPOXY](#)

SPECIFICATION

- Rescalable syringe
- Mixing tray and stick included
- Extremely strong bonding for metal to metal

EURO Offset Handrail Brackets

SOHO FIXED BRACKET - ROUND

SOHO CAP OPTIONS

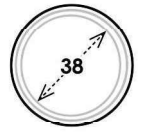
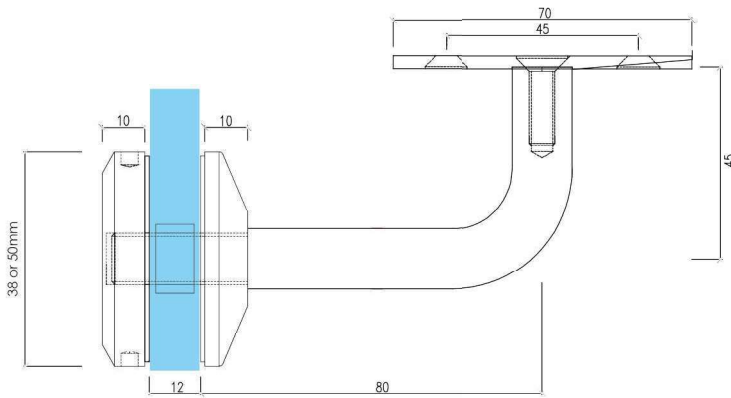

38mm Dia cap

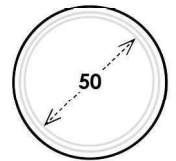

50mm Dia cap

SPECIFICATION

- Suitable for affixing to round or rectangular handrails: simply change the included saddle - flat or curved
- Easy to install! Use with our 970mm or 1280mm high, 12mm thick modular pre-drilled glass
- 38 or 50mm diameter bracket cap available
- Kit includes: flat saddle, 38 & 50.8mm curved saddles, handrail standoff body, nylon washers & stainless steel threaded rod

EURO OFFSET SOHO BRACKET - ROUND

Polish Or Satin Finish; STAINLESS STEEL 316

Order Code: **38mm DIA CAP**

EOS-SFB-FC38-P (polish finish)

EOS-SFB-FC38-S (satin finish)

50mm DIA CAP

EOS-SFB-FC50-P (polish finish)

EOS-SFB-FC50-S (satin finish)

Kit Includes: 3 Saddles



Suits 38mm diameter handrail



Suits 50.8mm diameter handrail



Flat Handrail

4 VERSATILE SOHO FIXING OPTIONS

NO SADDLE

DISCARD SADDLES PROVIDED.
SUITED FOR WELDING HANDRAILS

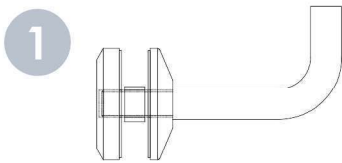

FLAT SADDLE

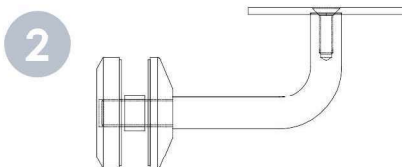

FLAT SADDLE & BRACKET ELEVATION VIEW

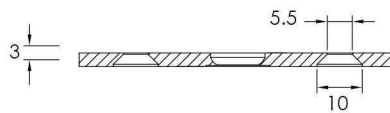

FLAT SADDLE SECTION VIEW

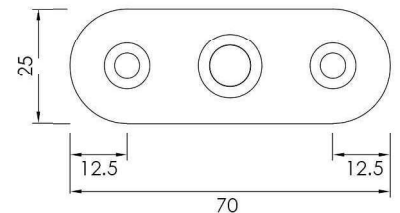

FLAT SADDLE PLAN VIEW

CURVED SADDLE

SUITS 38MM DIA & 50.8MM HANDRAIL

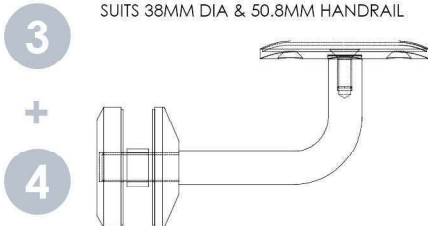

CURVED SADDLES & BRACKET ELEVATION VIEWS

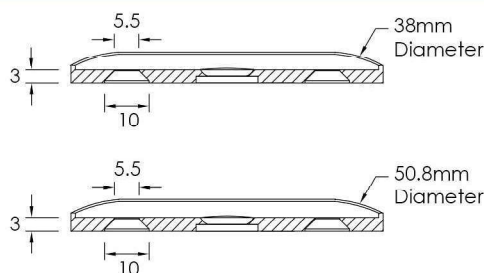

CURVED SADDLES SECTION VIEWS

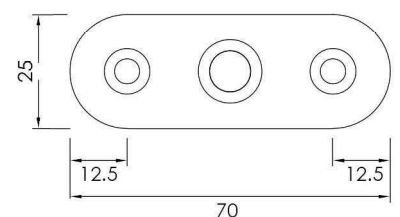

38 & 50.8mm CURVED SADDLE PLAN VIEW

NOTE: ALL DRAWINGS ARE NOT TO SCALE

EURO Offset Handrail Brackets

EURO OFFSET ADJUSTABLE HORIZONTAL BRACKET WITH FIXED VERTICAL BRACKET



Select 38mm or 50.8mm cap horizontal connector to match vertical fixed bracket

EURO OFFSET ADJUSTABLE HORIZONTAL BRACKET

Polish Or Satin Finish

Order Code: **38MM DIA CAP**

EOS-AB-H38-P (polish finish)

EOS-AB-H38-S (satin finish)

50MM DIA CAP

EOS-AB-H50-P (polish finish)

EOS-AB-H50-S (satin finish)

SPECIFICATION

- With 38mm or 50mm dia. cap
- Stainless steel 316

EURO OFFSET VERTICAL FIXED BRACKET

INCLUDES 3 SADDLES

Polish Or Satin Finish

Order Code: **EOS-AB-VF3S-P** (polish finish)

EOS-AB-VF3S-S (satin finish)

SPECIFICATION

- With vertical adjustability; choice of 3 fixed saddles
- Suitable for all euro offset handrail
- Stainless steel 316

STAINLESS STEEL HANDRAIL

EURO OFFSET ADJUSTABLE HORIZONTAL BRACKET WITH SWIVEL VERTICAL BRACKET



Select 38mm or 50.8mm cap horizontal connector to match vertical swivel bracket

EURO OFFSET ADJUSTABLE HORIZONTAL BRACKET

Polish Or Satin Finish

Order Code: **38MM DIA CAP**

EOS-AB-H38-P (polish finish)

EOS-AB-H38-S (satin finish)

50MM DIA CAP

EOS-AB-H50-P (polish finish)

EOS-AB-H50-S (satin finish)

SPECIFICATION

- With 38mm or 50mm dia. cap
- Stainless steel 316

EURO OFFSET VERTICAL SWIVEL BRACKET

INCLUDES 3 SADDLES

Polish Or Satin Finish

Order Code: **EOS-AB-VS3S-P** (polish finish)

EOS-AB-VS3S-S (satin finish)

SPECIFICATION

- With vertical adjustability; choice of 3 fixed saddles
- Suitable for all euro offset handrail
- Stainless steel 316
- Ideal for staircases: swivel & height adjustment provides ease of install

NOTE: ALL DRAWINGS ARE NOT TO SCALE

MOD50 COMPONENTS - ROUND

TUBE - 50.8MM ROUND STAINLESS STEEL

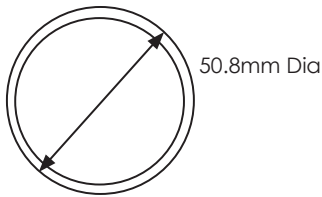

5800MM LENGTH

SPECIFICATION

- Available in 5800mm lengths; high polish finish
- 1.5mm wall thickness
- Stainless Steel 316L - low carbon stainless steel

5800mm STAINLESS STEEL TUBE, 50.8MM Polish Finish

Order Code: [MOD50-5800C-50D-P](#) (polish finish)

MOD 50 ROUND POSTS

POSTS - 50.8MM ROUND STAINLESS STEEL

SPECIFICATION

- Pre-welded base plated posts : 1000mm & 1300mm high
- Core drill pre cut posts – 1150mm and 1400mm high
- High Polish finish; 1.5mm wall thickness

STAINLESS STEEL POSTS, 50.8MM Polish Finish - Various Lengths

Order Code: **BASE PLATED POSTS:**
[MOD50-1000-BP-P](#) (polish finish)
[MOD50-1300-BP-P](#) (polish finish)

CORE DRILL POSTS:
[MOD50-1150-P](#) (polish finish)
[MOD50-1400-P](#) (polish finish)

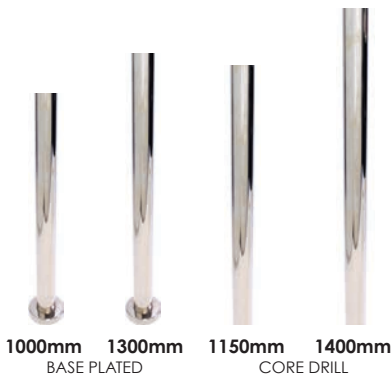

MOD 50 ROUND HEAVY DUTY POSTS

50.8MM ROUND STAINLESS STEEL POSTS



SPECIFICATION

- Heavy duty 3mm wall thickness
- Ideal post for hinging a glass gate or use as a terminating post for wire balustrading
- Pre-base plated – 1300mm high
Core drill – 1400mm and 2800mm high

HEAVY DUTY STAINLESS STEEL POSTS, 50.8MM Polish Finish - Various Lengths

Order Code: **BASE PLATED POSTS:**
[MOD50-1300-HDBP-P](#) (polish finish)

CORE DRILL POSTS:
[MOD50-1400-HD-P](#) (polish finish)
[MOD50-2800-HD-P](#) (polish finish)



NOTE: ALL DRAWINGS ARE NOT TO SCALE

MOD50 COMPONENTS - ROUND



JOINER
316 STAINLESS STEEL
Polish Finish
Order Code: **MOD50-J-P** (polish finish)

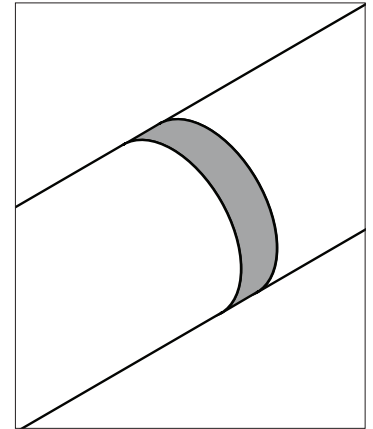
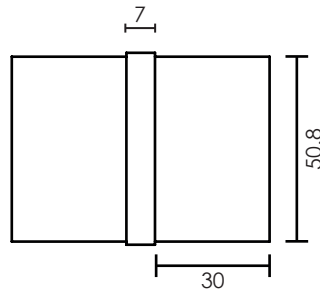

SPECIFICATION

- Inline joiner; easy to use tap-in fitting
- Suits 1.5mm wall thickness tube
- Epoxy glue, weld or drill/tap tube for joining strength



90 DEGREE JOINER
316 STAINLESS STEEL
Polish Finish
Order Code: **MOD50-J90-P** (polish finish)

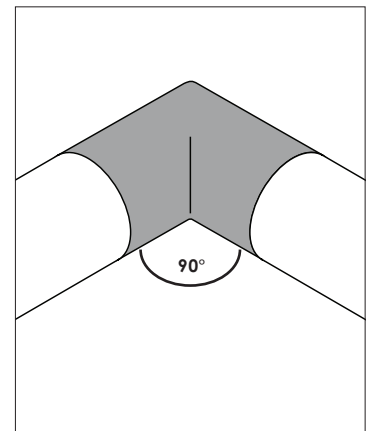
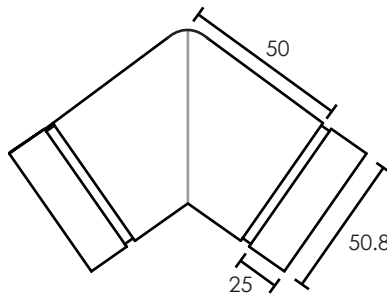

SPECIFICATION

- 90 degree joiner; easy to use tap-in fitting
- Suits 1.5mm wall thickness tube
- Epoxy glue, weld or drill/tap tube for joining strength



RADIUS 90 DEGREE JOINER
316 STAINLESS STEEL
Polish Finish
Order Code: **MOD50-J90R-P** (polish finish)

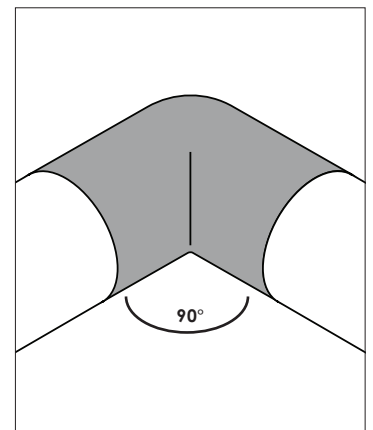
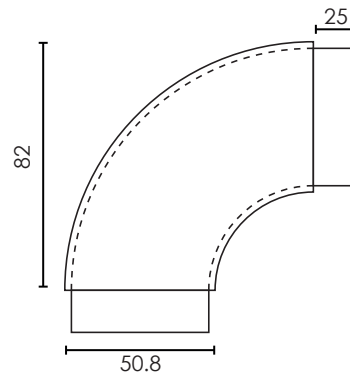

SPECIFICATION

- 90 degree joiner with radius; easy to use tap-in fitting
- Suits 1.5mm wall thickness tube
- Epoxy glue, weld or drill/tap tube for joining strength

VARIABLE
ANGLE



SWIVEL JOINER
316 STAINLESS STEEL
Polish Finish
Order Code: **MOD50-JS-P** (polish finish)

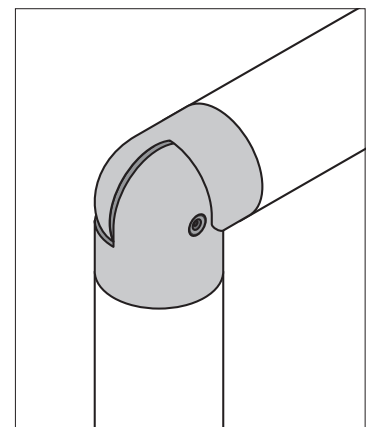
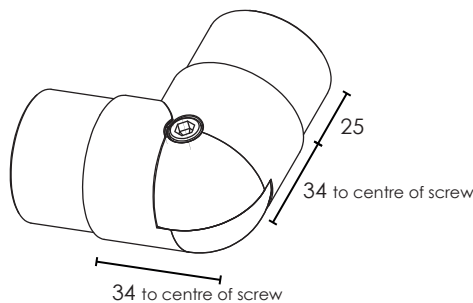

SPECIFICATION

- Adjustable 'swivel' joiner; angle from 90 to 180 degree achievable
- Suits 1.5mm wall thickness tube
- Epoxy glue, weld or drill/tap tube for joining strength

MOD50 COMPONENTS - ROUND



135 DEGREE JOINER
316 STAINLESS STEEL
Polish Finish
Order Code: **MOD50-J135-P** (polish finish)

SPECIFICATION

- 135 degree joiner; easy to use tap-in fitting
- Suits 1.5mm wall thickness tube
- Epoxy glue, weld or drill/tap tube for joining strength

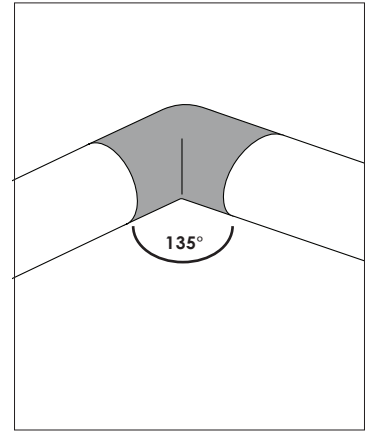
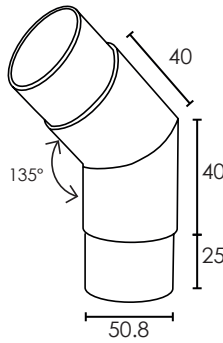

ADJUSTABLE BEND JOINER
316 STAINLESS STEEL
Polish Finish
Order Code: **MOD50-JAB-P** (polish finish)

SPECIFICATION

- Adjustable bend joiner; easy to use tap-in fitting
- Suits 1.5mm wall thickness tube
- Epoxy glue, weld or drill/tap tube for joining strength

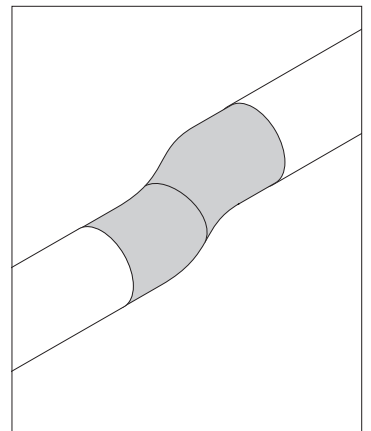
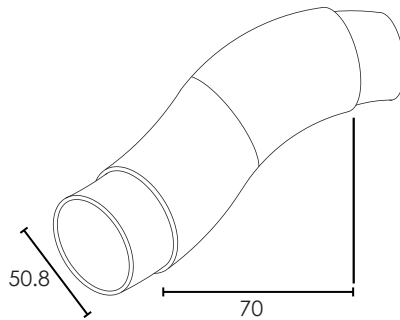

T JOINER
316 STAINLESS STEEL
Polish Finish
Order Code: **MOD50-JT-P** (polish finish)

SPECIFICATION

- Inline "T" joiner; easy to use tap-in fitting
- Suits 1.5mm wall thickness tube
- Epoxy glue, weld or drill/tap tube for joining strength

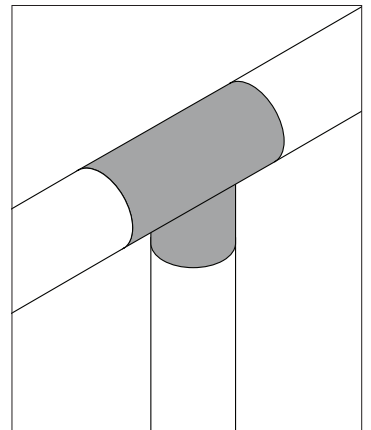
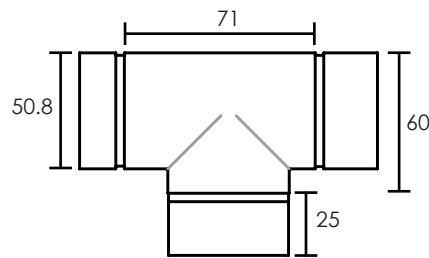

T 90 DEGREE JOINER
316 STAINLESS STEEL
Polish Finish
Order Code: **MOD50-J90T-P** (polish finish)

SPECIFICATION

- 90 degree "T" joiner; easy to use tap-in fitting
- Suits 1.5mm wall thickness tube
- Epoxy glue, weld or drill/tap tube for joining strength

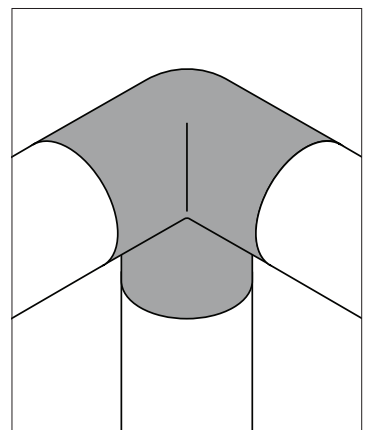
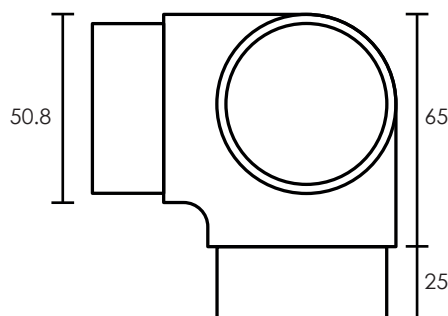



MOD50 COMPONENTS - ROUND



DOME END CAP
316 STAINLESS STEEL
Polish Finish
Order Code: **MOD50-ECD-P** (polish finish)

SPECIFICATION

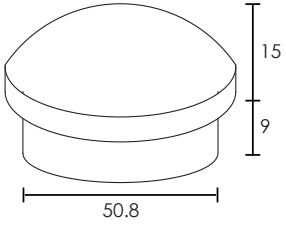
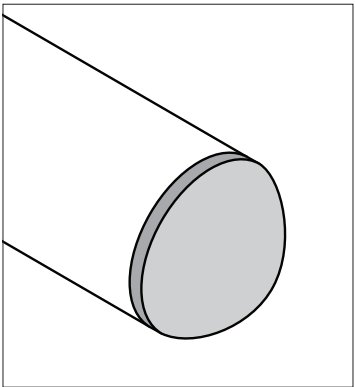

- Domed end cap; easy to use tap-in fitting
- Suits 1.5mm wall thickness tube
- Epoxy glue, weld or drill/tap tube for joining strength

FLAT END CAP
316 STAINLESS STEEL
Polish Finish
Order Code: **MOD50-ECF-P** (polish finish)

SPECIFICATION

- Flat end cap; easy to use tap-in fitting
- Suits 1.5mm wall thickness tube
- Epoxy glue, weld or drill/tap tube for joining strength

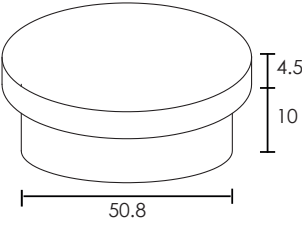
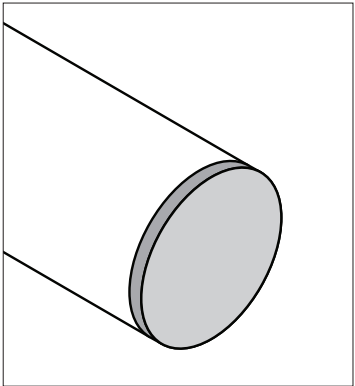



HEAVY DUTY

MOD50 HEAVY DUTY TOP CAP
316 STAINLESS STEEL
Polish Finish
Order Code: **MOD50-HDTC-P** (polish finish)

SPECIFICATION

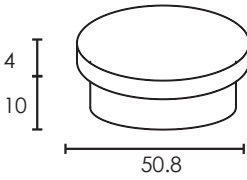
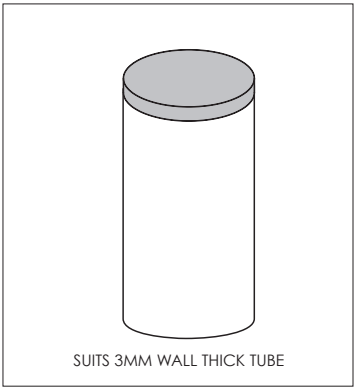
- Top cap to suit 50.8mm tube with 3mm wall thickness
- Suits MOD50 heavy duty post range



SUITS 3MM WALL THICK TUBE



HANDRAIL CURVED END
316 STAINLESS STEEL
Polish Finish
Order Code: **MOD50-HEC-P** (polish finish)

SPECIFICATION

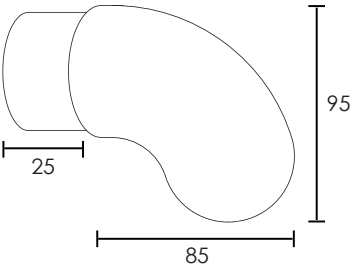
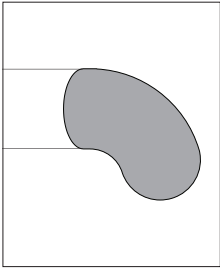
- Handrail end curve: 90 degree; easy to use tap-in fitting
- Suits 1.5mm wall thickness tube
- Epoxy glue, weld or drill/tap tube for joining strength

HANDRAIL END U SHAPE
316 STAINLESS STEEL
Polish Finish
Order Code: **MOD50-HEU-P** (polish finish)

SPECIFICATION

- Handrail end curve: 180 degree; easy to use tap-in fitting
- Suits 1.5mm wall thickness tube
- Epoxy glue, weld or drill/tap tube for joining strength

MOD50 COMPONENTS - ROUND

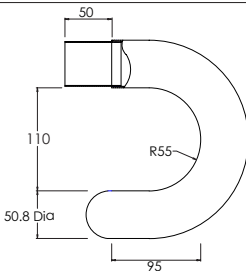
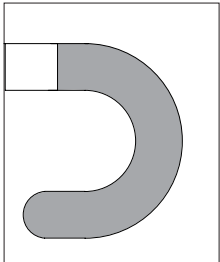
WALL BRACKET
316 STAINLESS STEEL
Polish Finish
Order Code: **MOD50-WB-P** (polish finish)

SPECIFICATION

- Wall bracket: clamping action holds 50.8 tube in place
- Consider welding tube to bracket connectors for extra strength
- 2 x 11mm diameter holes: 80mm centres

MOD50 OBLONG FLANGE
316 STAINLESS STEEL
Polish Finish
Order Code: **MOD50-BPF-O-P** (polish finish)

SPECIFICATION

- Oblong shape external fitting flange
- 4 x 6.5mm diam holes (with 11mm diam countersunk on top)
- Suits 50.8mm diam tube
- Epoxy glue, weld or drill/tap tube for joining strength

EXTENDED FLANGE WALL PLATE
Polish Finish
Order Code: **FB-50D-WP25-P** (polish finish)

SPECIFICATION

- EXTENDED mouth bracket can be affixed to wall/post
- 50.8mm tube fits into opening 25mm deep (female fit)
- Stainless Steel 316
- Epoxy glue, weld or drill/tap tube for joining strength

MOD50 ROUND BASE PLATE FLANGE
316 STAINLESS STEEL
Polish Finish
Order Code: **MOD50-BPF-R-P** (polish finish)

SPECIFICATION

- Round shape external fitting flange
- 3 x 6.5mm diam holes (with 11mm diam countersunk on top)
- Suits 50.8mm diam tube

MOD50 ROUND DRESS RING
316 STAINLESS STEEL
Polish Finish
Order Code: **MOD50-DR-P** (polish finish)

SPECIFICATION

- Suits 50.8mm diameter tube
- 100mm outer diameter, 51.5mm inner diameter

MOD50 BASE PLATE
316 STAINLESS STEEL
Polish Finish
Order Code: **MOD50-BP-P** (polish finish)

SPECIFICATION

- 93mm outer diameter round base plate
- 8mm thick ; 3 x 11mm diam holes (with 16mm countersunk on top)
- Suits welding 50.8mm diam tube to base plate

MOD50 DOMICAL COVER
316 STAINLESS STEEL
Polish Finish
Order Code: **MOD50-DC-P** (polish finish)

SPECIFICATION

- Slimline 20mm high domical cover
- Suits 50.8mm diam tube

NOTE: ALL DRAWINGS ARE NOT TO SCALE

MOD50 COMPONENTS - ROUND

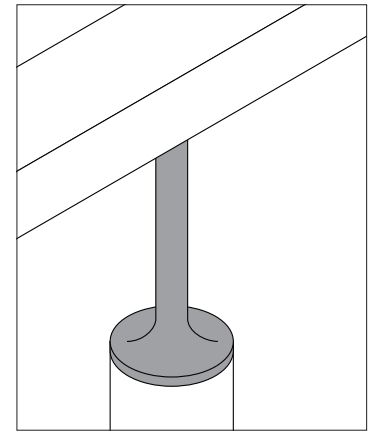
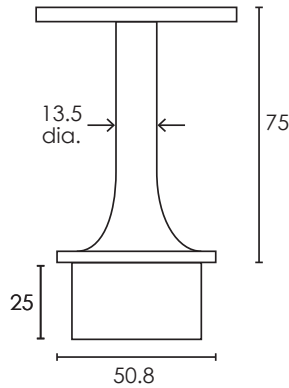
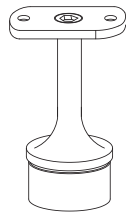

RAIL SUPPORT - FIXED FLAT SADDLE

316 STAINLESS STEEL

Polish Finish

Order Code: **MOD50-RS-FF-P** (polish finish)

SPECIFICATION

- Flush fitting post reducer with fixed flat saddle
- Saddle can be removed/discarded if desired
- Epoxy glue, weld or drill/tap tube for joining strength
- Suits 1.5mm wall thickness

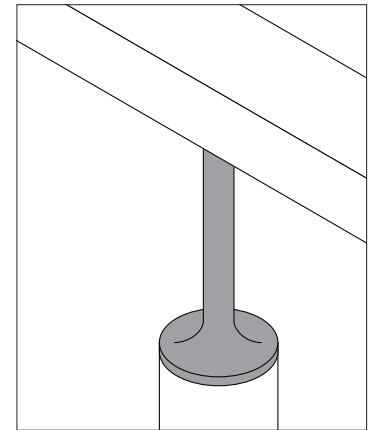
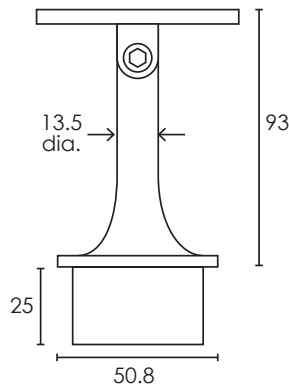

RAIL SUPPORT - SWIVEL FLAT SADDLE

316 STAINLESS STEEL

Polish Finish

Order Code: **MOD50-RS-SF-P** (polish finish)

SPECIFICATION

- Flush fitting post reducer with swivel flat saddle
- Ideal for staircases, Suits 50.8mm diam tube
- Epoxy glue, weld or drill/tap tube for joining strength
- Suits 1.5mm wall thickness

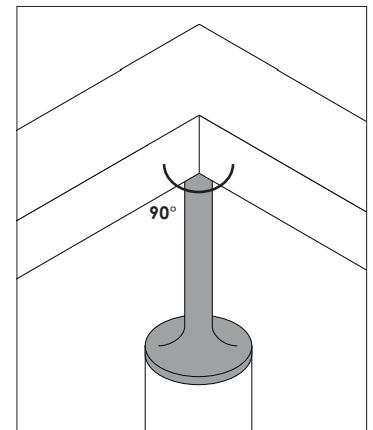
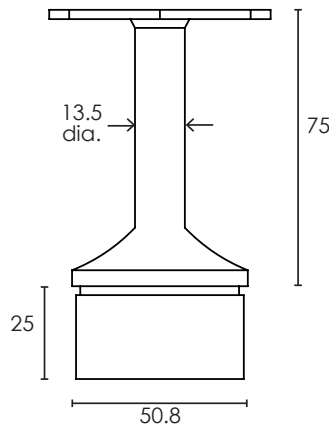

RAIL SUPPORT FIXED FLAT 90 DEGREE SADDLE

316 STAINLESS STEEL

Polish Finish

Order Code: **MOD50-RS-FF90-P** (polish finish)

SPECIFICATION

- Flush fitting post reducer with 90 degree fixed flat saddle
- Epoxy glue, weld or drill/tap tube for joining strength
- Suits 1.5mm wall thickness

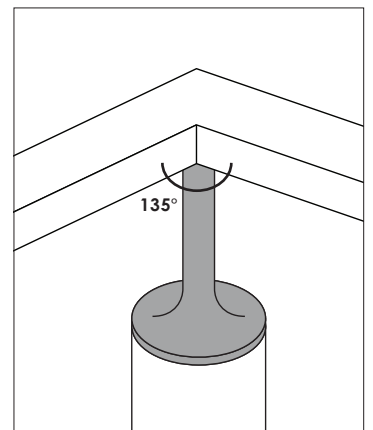
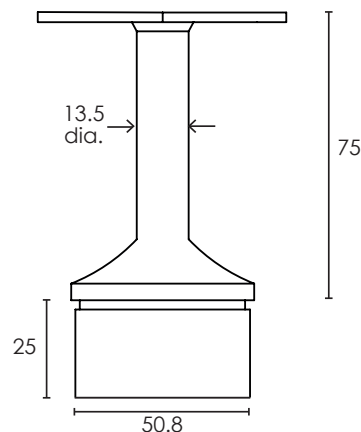

RAIL SUPPORT FIXED FLAT 135 DEGREE SADDLE

316 STAINLESS STEEL

Polish Finish

Order Code: **MOD50-RS-FF135-P** (polish finish)

SPECIFICATION

- Flush fitting post reducer with 135 degree fixed flat saddle
- Epoxy glue, weld or drill/tap tube for joining strength
- Suits 1.5mm wall thickness

MOD50 COMPONENTS - ROUND

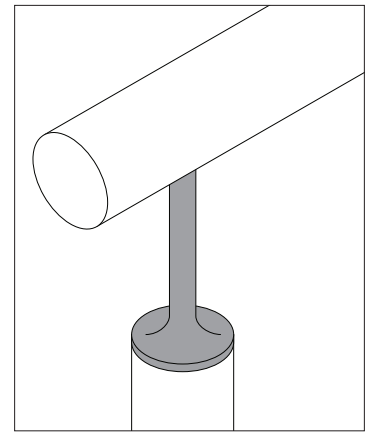
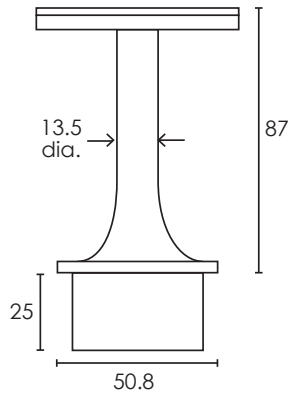
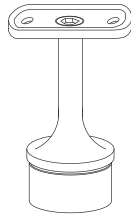

RAIL SUPPORT FIXED CURVED SADDLE
316 STAINLESS STEEL

Polish Finish

Order Code: **MOD50-RS-FC-P** (polish finish)

SPECIFICATION

- Flush fitting post reducer with fixed curved saddle
- Suits 50.8mm diam tube
- Epoxy glue, weld or drill/tap tube for joining strength
- Suits 1.5mm wall thickness

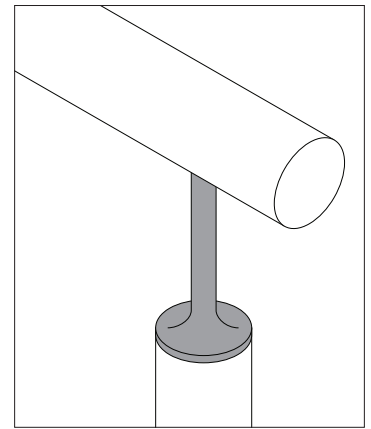
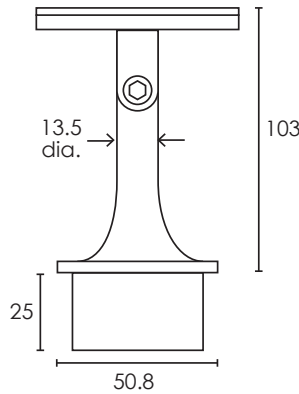

RAIL SUPPORT SWIVEL CURVED SADDLE
316 STAINLESS STEEL

Polish Finish

Order Code: **MOD50-RS-SC-P** (polish finish)

SPECIFICATION

- Flush fitting post reducer with swivel curved saddle
- Ideal for staircases. Suits 50.8mm diam tube
- Epoxy glue, weld or drill/tap tube for joining strength
- Suits 1.5mm wall thickness

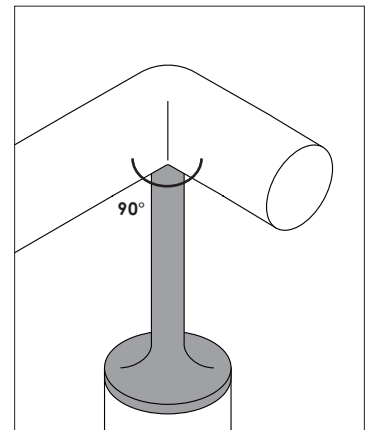
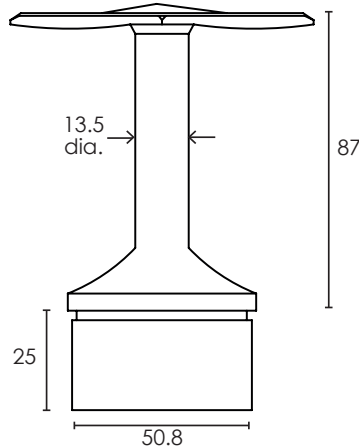

RAIL SUPPORT FIXED CURVED 90 DEGREE SADDLE
316 STAINLESS STEEL

Polish Finish

Order Code: **MOD50-RS-FC90-P** (polish finish)

SPECIFICATION

- Flush fitting post reducer with 90 degree curved saddle
- Suits 50.8mm diam tube
- Epoxy glue, weld or drill/tap tube for joining strength
- Suits 1.5mm wall thickness

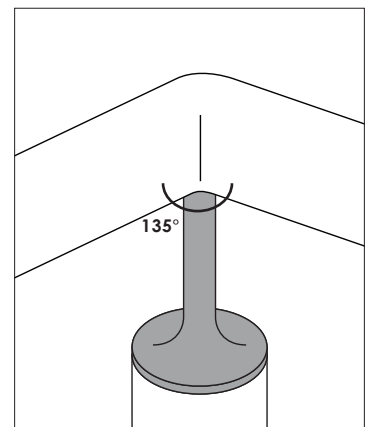
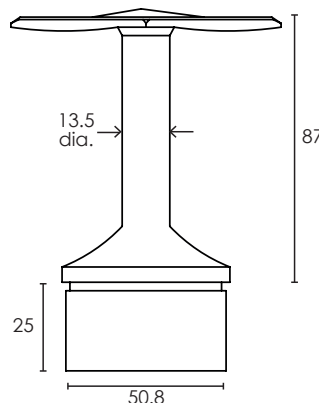

RAIL SUPPORT FIXED CURVED 135 DEGREE SADDLE
316 STAINLESS STEEL

Polish Finish

Order Code: **MOD50-RS-FC135-P** (polish finish)

SPECIFICATION

- Flush fitting post reducer with 135 degree curved saddle
- Suits 50.8mm diam tube
- Epoxy glue, weld or drill/tap tube for joining strength
- Suits 1.5mm wall thickness

NOTE: ALL DRAWINGS ARE NOT TO SCALE



MOD50 COMPONENTS - ROUND



WALL SUPPORT FIXED FLAT SADDLE
316 STAINLESS STEEL
Polish Finish
Order Code: [MOD50-RSW-FF-P](#) (polish finish)

SPECIFICATION

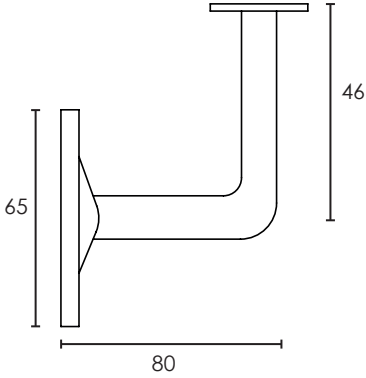
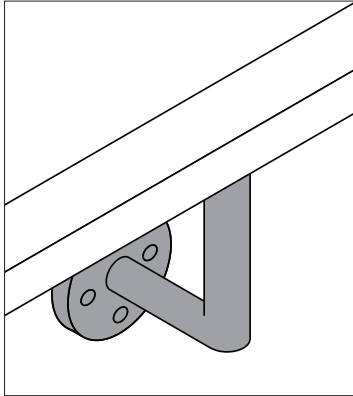

- 3 hole wall bracket for easy fitting to any surface
- Fixed flat saddle (can be removed/discarded if desired)
- Countersunk holes in saddle allow rail fixing without welding

WALL SUPPORT SWIVEL FLAT SADDLE
316 STAINLESS STEEL
Polish Finish
Order Code: [MOD50-RSW-SF-P](#) (polish finish)

SPECIFICATION

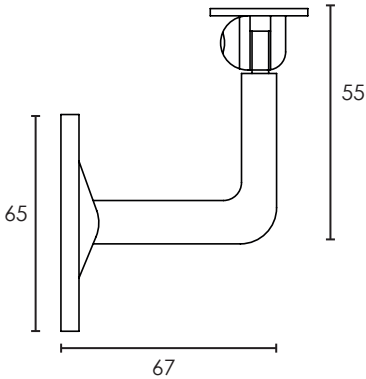
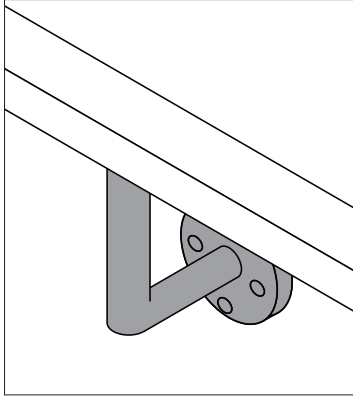

- 3 hole wall bracket for easy fitting to any surface
- Swivel flat saddle – ideal for staircases
- Countersunk holes in saddle allow rail fixing without welding

WALL SUPPORT FIXED CURVE SADDLE
316 STAINLESS STEEL
Polish Finish
Order Code: [MOD50-RSW-FC-P](#) (polish finish)

SPECIFICATION

- 3 hole wall bracket for easy fitting to any surface
- Fixed curved saddle to suit 50.8mm tube
- Countersunk holes in saddle allow rail fixing without welding

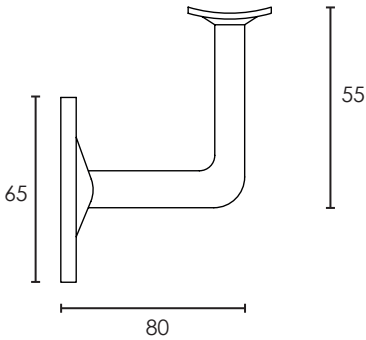
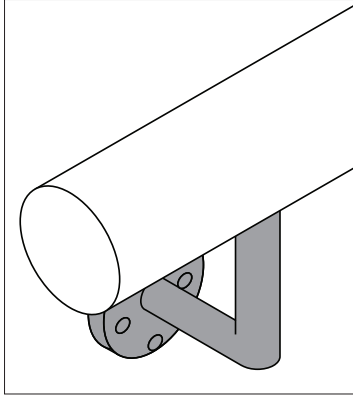
WALL SUPPORT SWIVEL CURVED SADDLE
316 STAINLESS STEEL
Polish Finish
Order Code: [MOD50-RSW-SC-P](#) (polish finish)

SPECIFICATION

- 3 hole wall bracket for easy fitting to any surface
- Swivel curved saddle to suit 50.8mm tube – ideal for staircases
- Countersunk holes in saddle allow rail fixing without welding



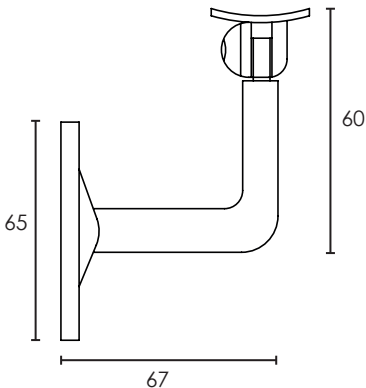
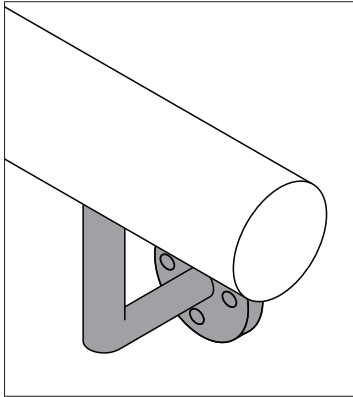

COVER FOR WALL SUPPORT
316 STAINLESS STEEL
Polish Finish
Order Code: [MOD50-RSW-C-P](#) (polish finish)

- SPECIFICATION**
- Slimline cover to hide fixings
 - Suits MOD50 wall brackets: [MOD50-RSW-FF-P](#) & [MOD50-RSW-FC-P](#) only.
 - Dimensions: 15mm High; 69mm dia. outer; 15mm dia. inner hole

NOTE: ALL DRAWINGS ARE NOT TO SCALE

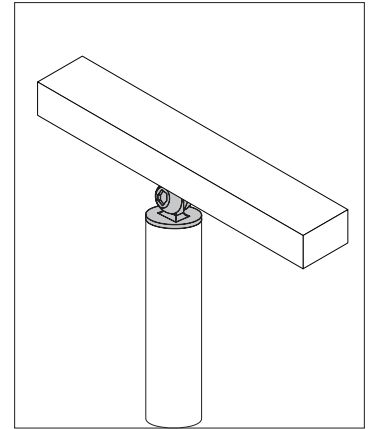
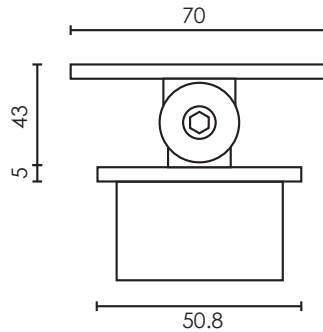
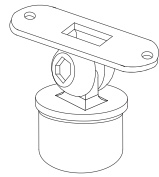
MOD50 COMPONENTS - ROUND



RAIL SUPPORT BALL JOINER WITH SWIVEL FLAT SADDLE

316 STAINLESS STEEL

Polish Finish

Order Code: **MOD50-RSB-SF-P** (polish finish)

SPECIFICATION

- Adjustable 'swivel' support with flat saddle: ideal for staircases
- Suits 1.5mm wall thickness tube
- Also, can be used to terminate a 50.8 tube at an angled position
- Epoxy glue, weld or drill/tap tube for joining strength

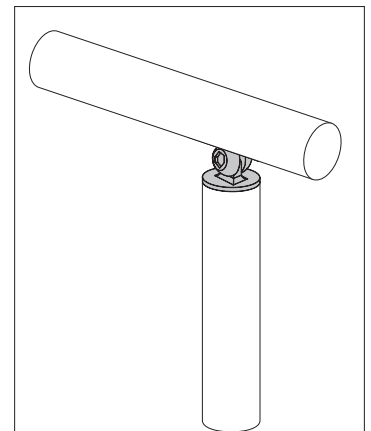
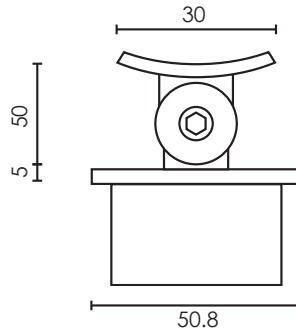

RAIL SUPPORT BALL JOINER WITH SWIVEL CURVED SADDLE

316 STAINLESS STEEL

Polish Finish

Order Code: **MOD50-RSB-SC-P** (polish finish)

SPECIFICATION

- Adjustable 'swivel' support with curved saddle: ideal for staircases
- Suits 1.5mm wall thickness tube and 50.8mm diam tube
- Epoxy glue, weld or drill/tap tube for joining strength

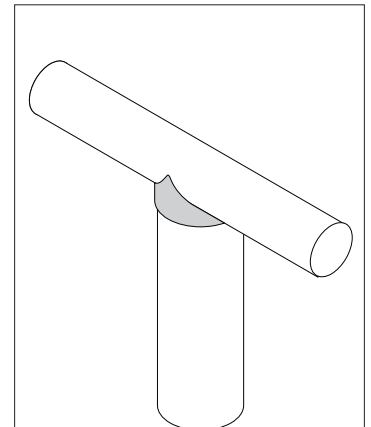
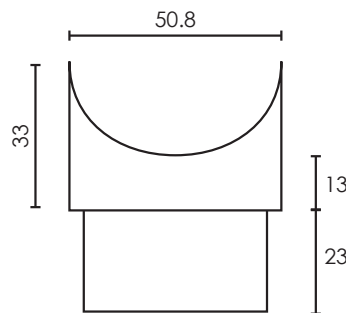
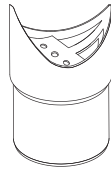

FLUSH RAIL SUPPORT

316 STAINLESS STEEL

Polish Finish

Order Code: **MOD50-RSF-P** (polish finish)

SPECIFICATION

- Flush fitting joiner: internally affixed to rail with screws/rivets
- Use to join vertical post to handrail or horizontal rail to post
- Suits 1.5mm wall thickness tube
- Epoxy glue, weld or drill/tap tube for joining strength

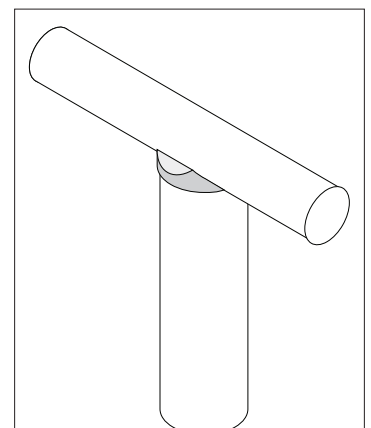
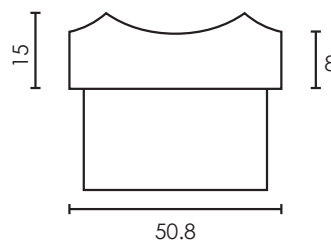
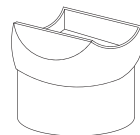

TAPERED RAIL SUPPORT

316 STAINLESS STEEL

Polish Finish

Order Code: **MOD50-RSF-T-P** (polish finish)

SPECIFICATION

- Tapered rail joiner : internally affixed to rail with screws/rivets
- 1 x 9mm fixing hole in centre
- Use to join vertical post to handrail or horizontal rail to post
- Suits 1.5mm wall thickness tube
- Epoxy glue, weld or drill/tap tube for joining strength

NOTE: ALL DRAWINGS ARE NOT TO SCALE

MOD50 COMPONENTS - ROUND

**SUITABLE
FOR WELDING
TO
HANDRAILS**



RAIL CONVERTOR
316 STAINLESS STEEL
Polish Finish

Order Code: **MOD50-RC-W-P** (polish finish)

SPECIFICATION

- Weld to horizontal stainless steel top rails
- Suits 1.5mm wall thickness tube
- Affix to vertical post with epoxy glue, weld or drill/top

MOD SERIES INSTALLATION ACCESSORIES



M8 Blind Rivet Nut
Sold Individually

Order Code:
MOD-M8-BRN

- Thread inserts for affixing clamps to posts
- 304 stainless steel
- **Suits 0.5 to 3mm wall thickness posts**
- Insert using the hand rivet nut tool



M8 x 20 Cap Screw
Sold Individually

Order Code:
MOD-M8-CS

- Use with blind rivet nut to affix glass clamp to post
- 304 stainless steel



Rivet Nut Hand Tool
Hand Operated

Order Code:
MOD-RIV-TOOL

- Allows quick insertion of stainless rivet nuts into posts
- Push/pull rod for quick thread insert and release
- Includes M4, M5, M6, M8 & M10 mandrel set
- **Adjustable stroke for different wall thickness on posts (0.5mm to 3mm)**

EASY CLAMP INSTALL GUIDE

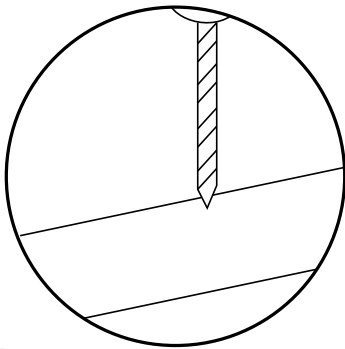

1 DRILL HOLE IN POST
MARK OUT & DRILL HOLES TO
SUIT DIAMETER OF BLIND RIVET NUT

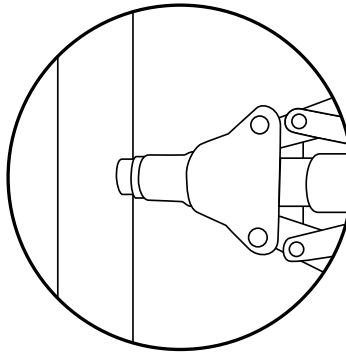

2 INSTALL THE BLIND RIVET NUT
USING THE RIVET HAND TOOL

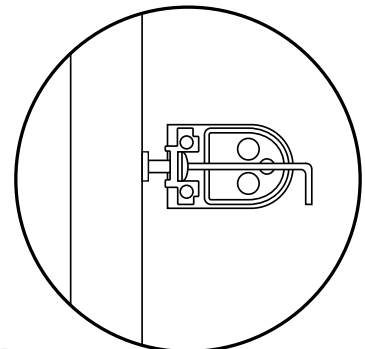

3 INSTALL THE D CLAMP ONTO POST
SCREW THE CAP HEAD SCREW INTO
THE BLIND RIVET NUT THROUGH THE
D CLAMP

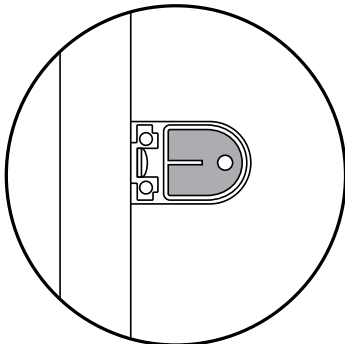

4 PLACE RUBBER GASKETS
PLACE THE CORRECT RUBBER
GASKETS ONTO BOTH HALVES
OF THE D CLAMP

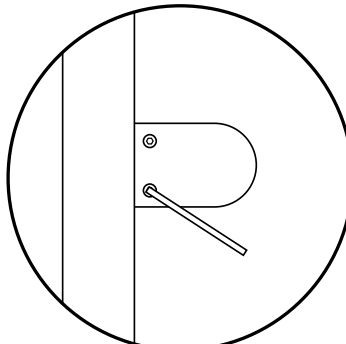

5 INSERT GLASS & TIGHTEN
PLACE GLASS INTO POSITION &
TIGHTEN THE SECOND HALF OF
THE D CLAMP

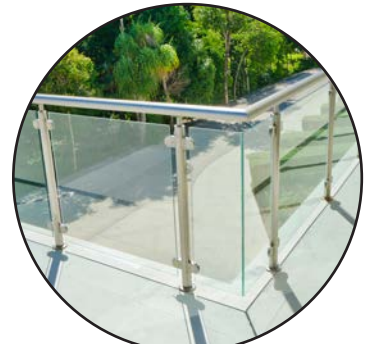

...finished!

NOTE: ALL DRAWINGS ARE NOT TO SCALE