

BLITZ GLASS

Installation Tips



www.blitzglass.com.au



(07) 5493 9779



admin@blitzglass.com.au

Xpressscreen configurations

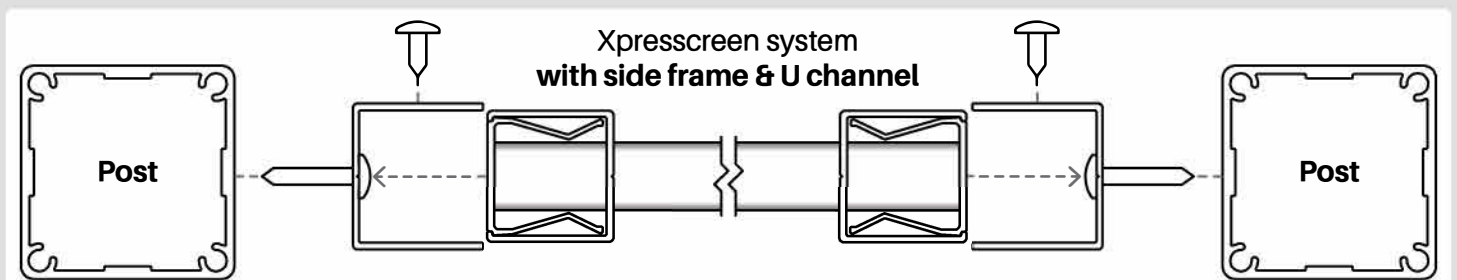
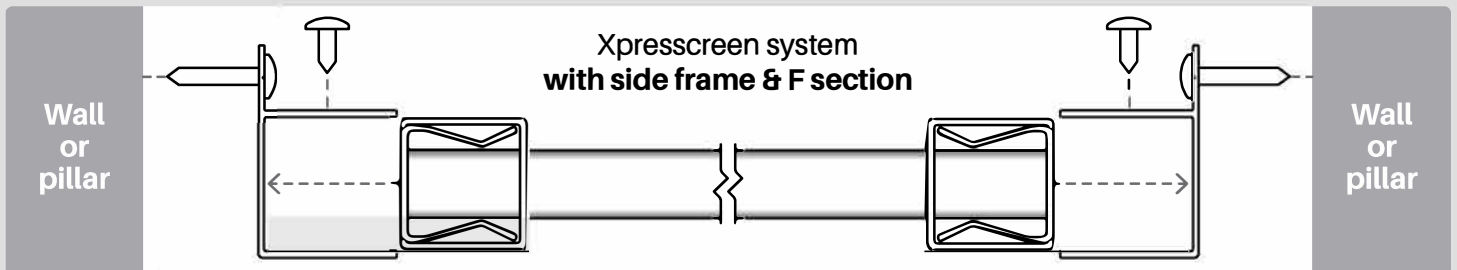
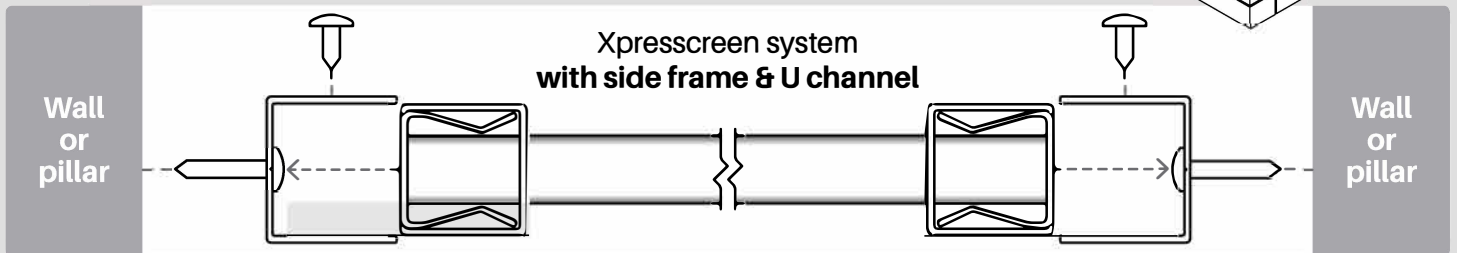
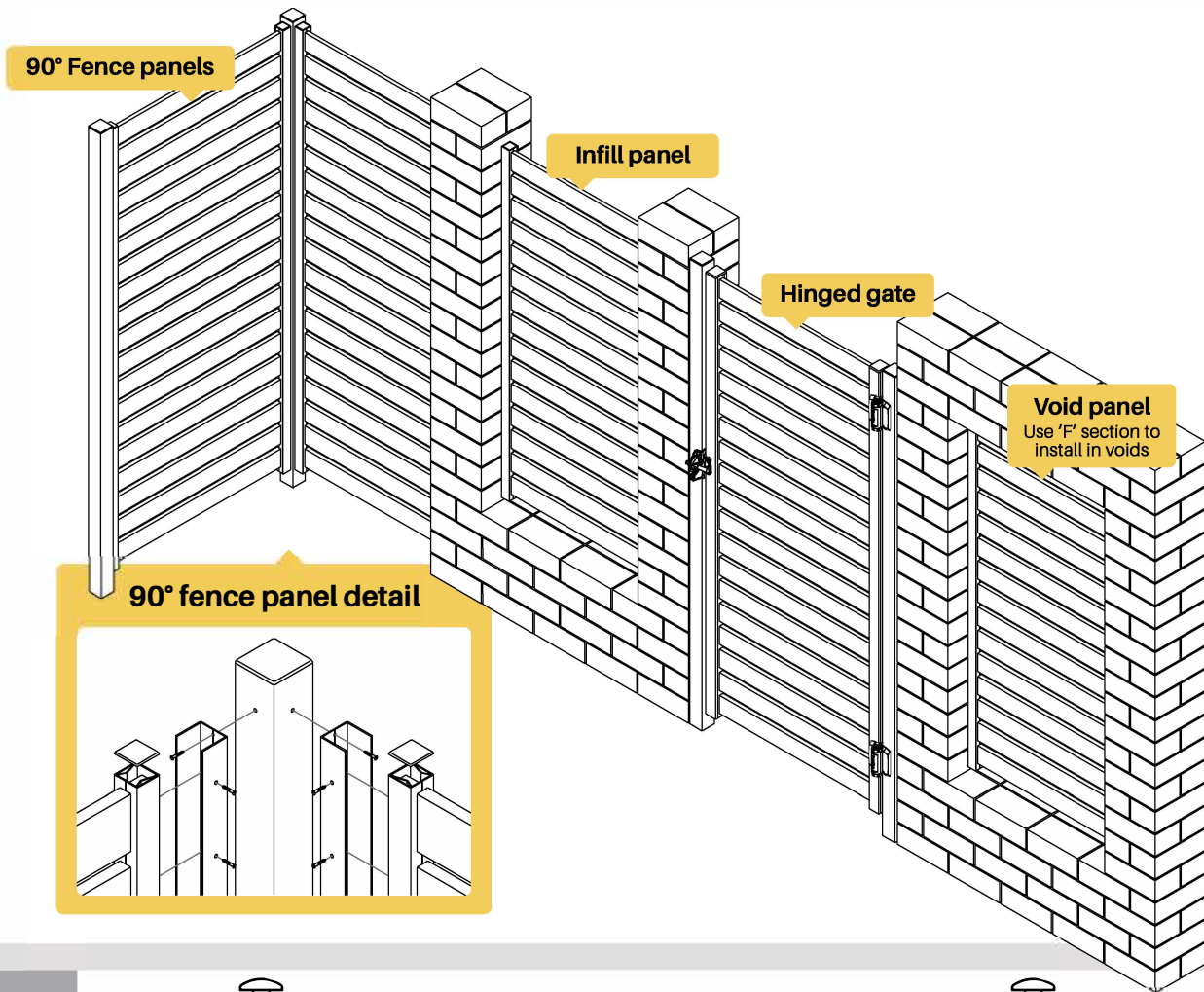

Trade tip: If buying long lengths and cutting on-site, a deduction of 17mm off the overall slat length is required to ensure built frame fits inside U or F section

Xpressscreen panel installation

PATENTED EASY XPRESS ASSEMBLY SYSTEM

Patented easy Xpressscreen assembly system

Innovative frame designed to grip each slat ensuring a solid and rattle free panel without the need for welding or screwing.

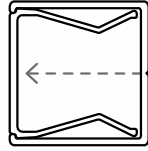

NO SCREWS OR RIVETS!

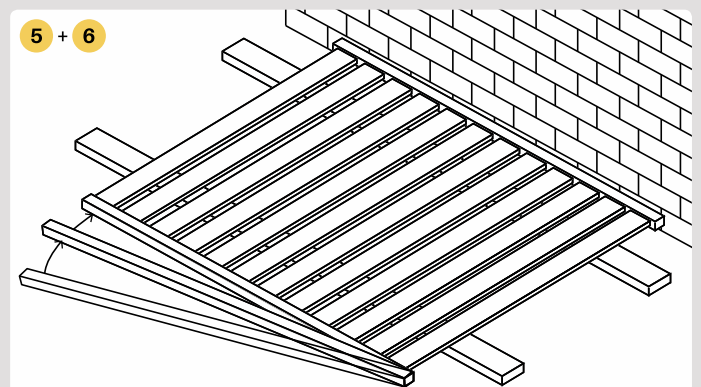
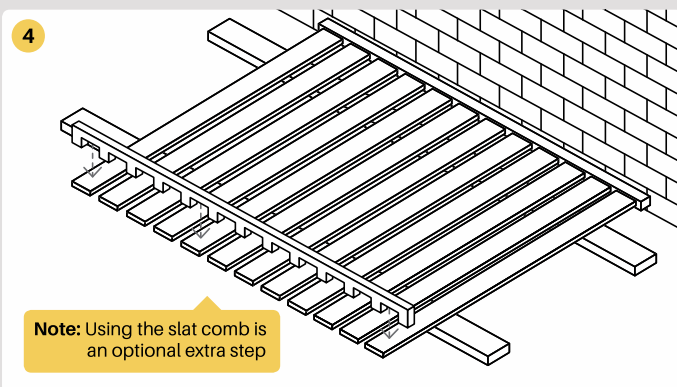
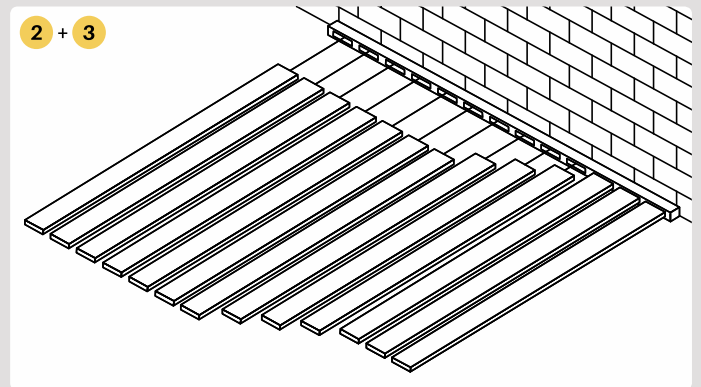
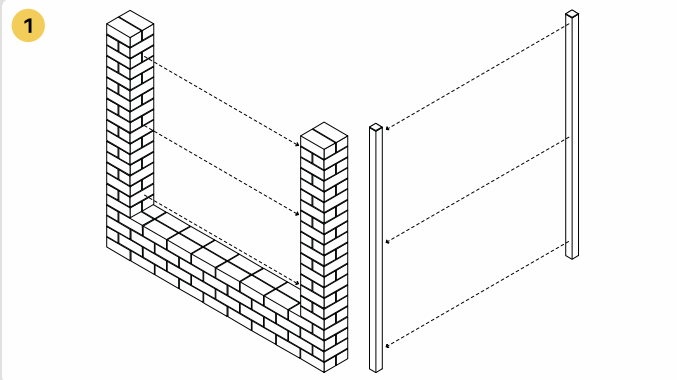
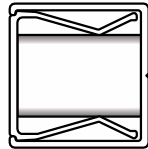

- 1** Take measurement between walls or posts at 3 points: top, middle and bottom (Take note of the smallest measurement)
- 2** Place machined frame on flat surface and insert slats into machined holes in the frame
(Make sure surface is protected from scratching)
- 3** One at a time, push the slats in to the side frame until they are fully engaged
(If necessary, tap the ends of the slats with a rubber mallet to make sure the slats are in as far as possible)
- 4** Elevate slats & side frame on 2 padded bearers. Place the slat comb between slats to prevent any movement of slats in the next step
- 5** Starting from the left side, feed the slats one at a time into the side frame. Slowly rotate the side frame and engage the other slats, one at a time until they are all inserted
(When all slats are engaged, push down along the length of the frame)
- 6** Using the rubber mallet, tap the top of the machined frame along its length, until slats and side frame are fully engaged

Quickscreen configurations

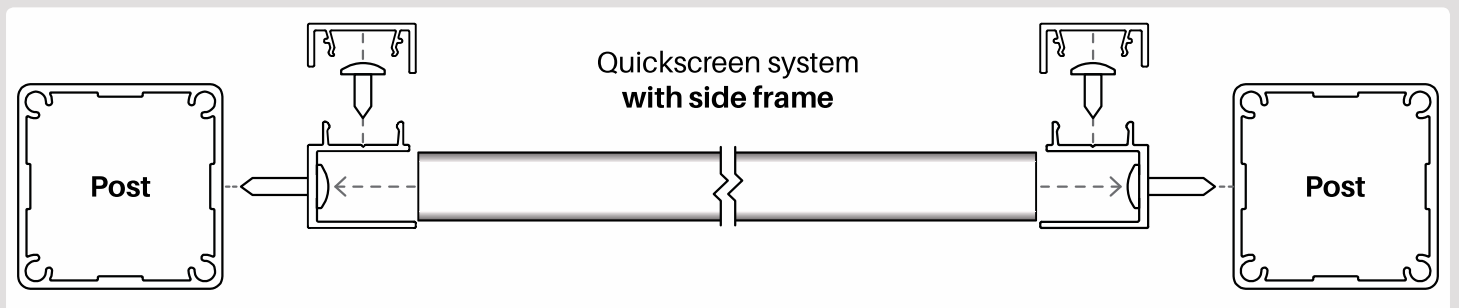
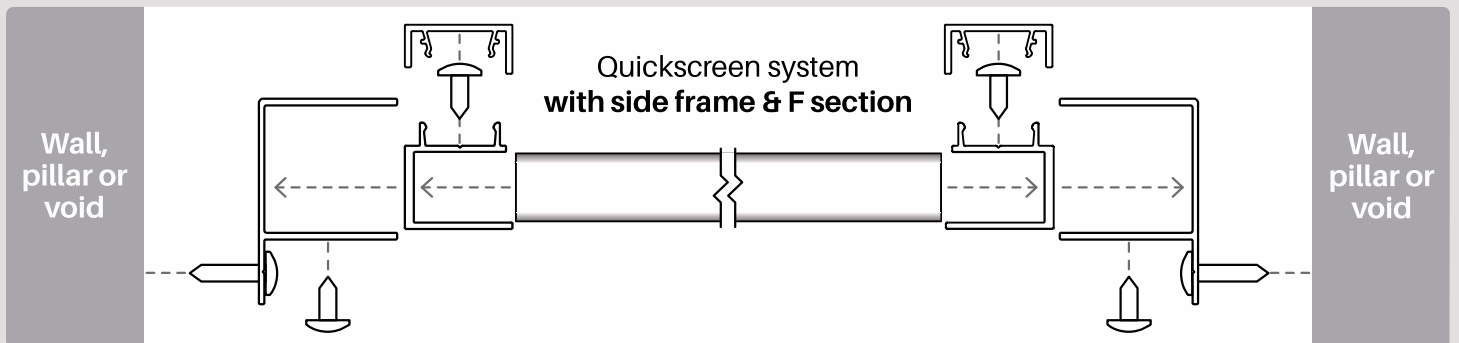
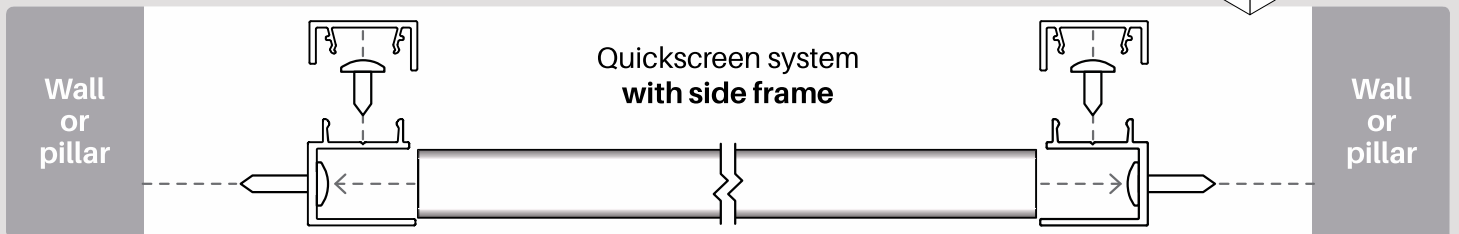
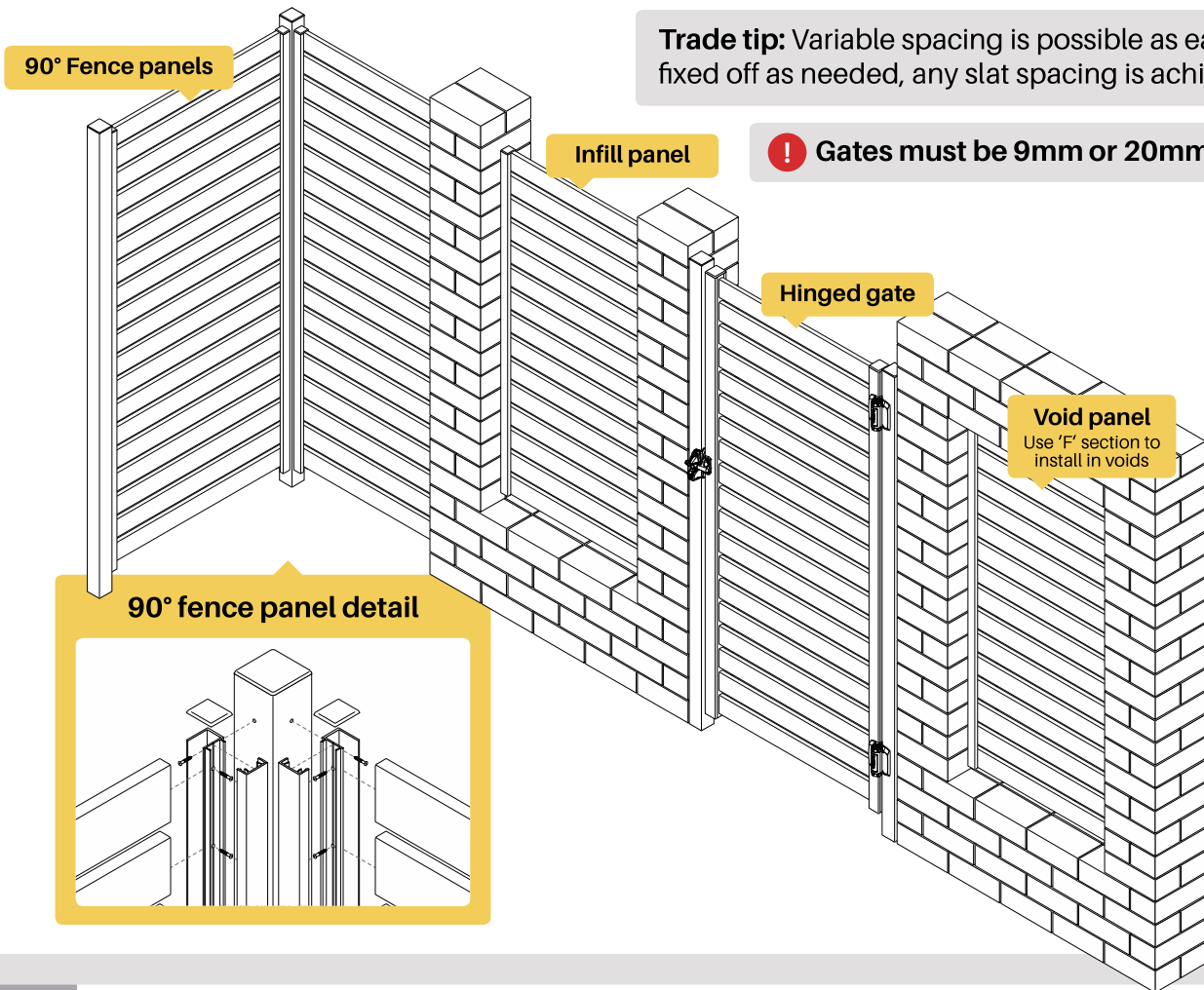

Quickscreen panel installation

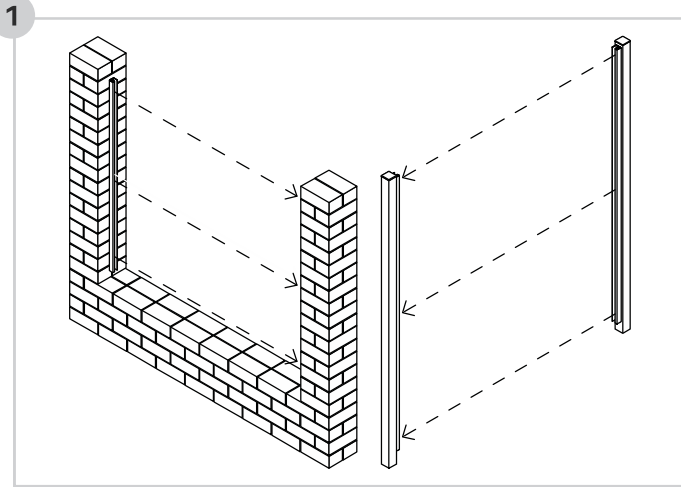

1
Take measurement between walls or posts at 3 points: top, middle and bottom (Take note of the smallest measurement)

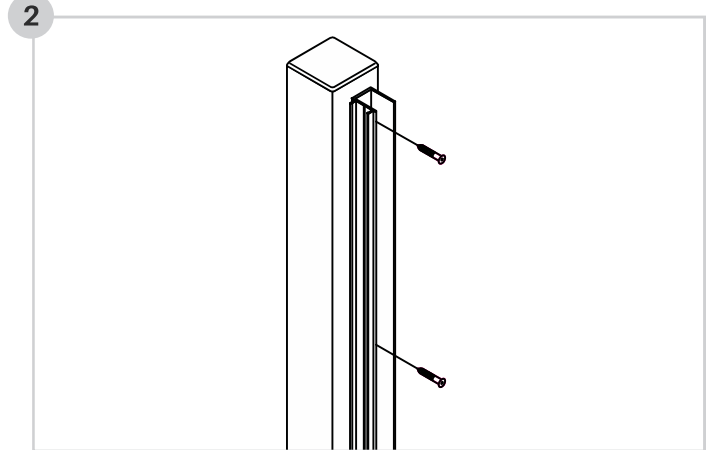

2
Cut side frames 3mm less than desired height (3mm allows for the top cap)
Affix side frames to wall or post with appropriate fixings

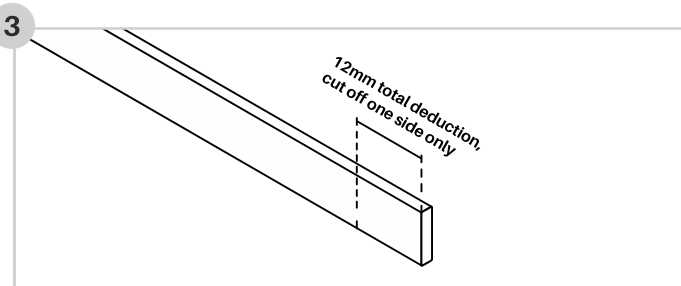

3
Cut aluminium slats 12mm less than total width of opening (Refer to measurement in step 1)
The 12mm deduction takes into account thickness of side frame on both sides of the screen and head of fixings.
Ensure fixings holding side frame do not obstruct slats when dropping in. If so, you may need to trim slats further.

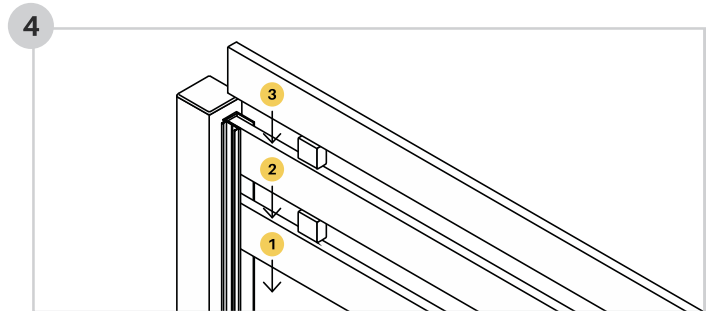

4
Drop in aluminium slats
Tip: Ensure bottom slat is level and screw off at both sides
Optional spacer blocks can be rotated to achieve a 9, 15 or 20mm slat gap. Any gap can be achieved by leaving a desired space. Consider using timber block spacers to achieve other gaps.

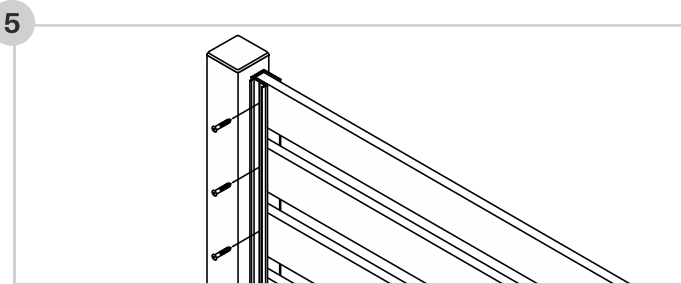

5
Screw off each slat as it is dropped in (ensuring each slat is level)
If spacer blocks used, remove after each level is installed.

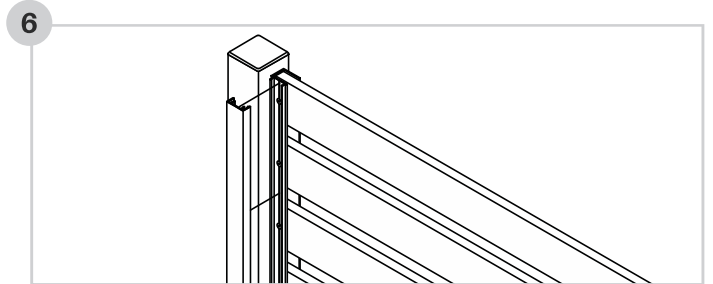

6
Cut snap on fixing cover to appropriate height
Attach snap on fixing cover to hide screws
Tip: If screen is wider than 1800mm, it is recommended to attach the centre support rail vertically at the centre of the screen. Cut centre support rail to appropriate height of screen and screw off to each slat at back side of screen

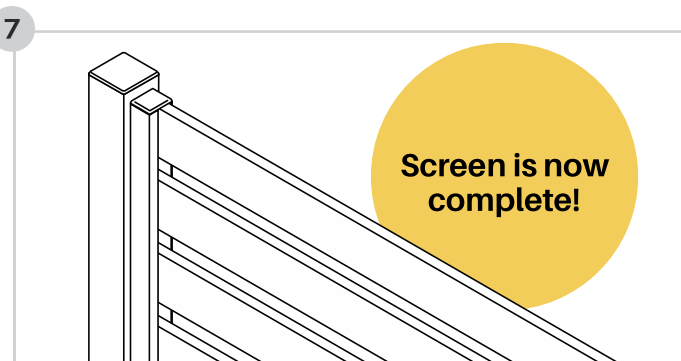

Snap on fixing cover install tip

Engage shorter leg of snap-on cover first.

At this point, the snap-on cover will be sitting off the side frame on an angle. The longer leg must be at open side of side frame.

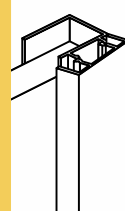

Starting from the top and working your way down, use a wood block and a hammer/mallet to tap the longer leg into place.

A short, sharp tap may be required to engage the long leg.

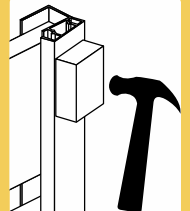

Gate configurations

Refer below for 'gate slat' positioning in conjunction with width & height specifications

9mm or 20mm slat spacing

Up to 1000mm wide

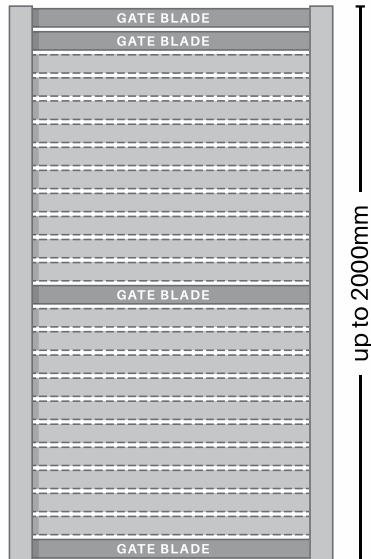

Gate blades:

- 2x top
- 1x middle
- 1x bottom



From 1001mm to 1200mm wide

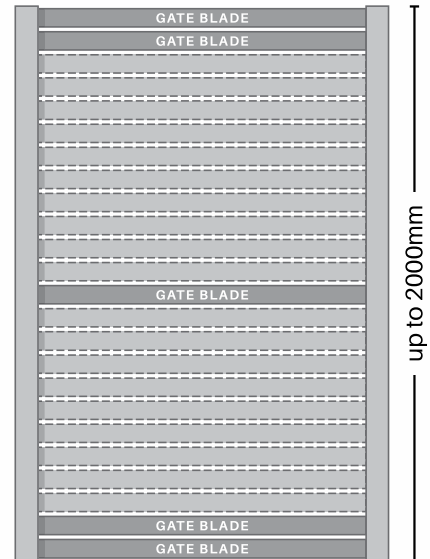

Gate blades:

- 2x top
- 1x middle
- 2x bottom



From 1201mm to 1500mm wide

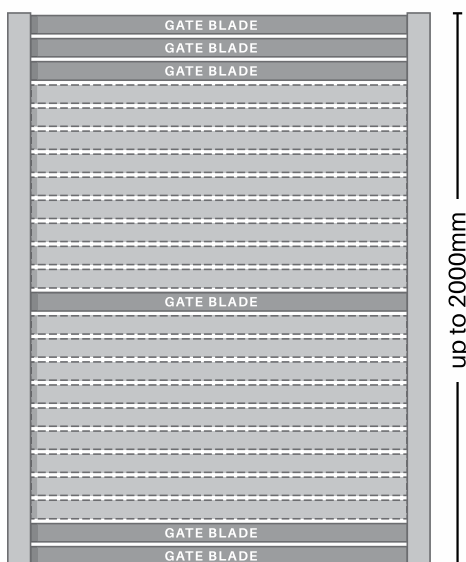

Gate blades:

- 3x top
- 1x middle
- 2x bottom



From 1501mm to 2100mm wide

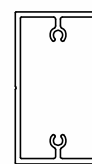
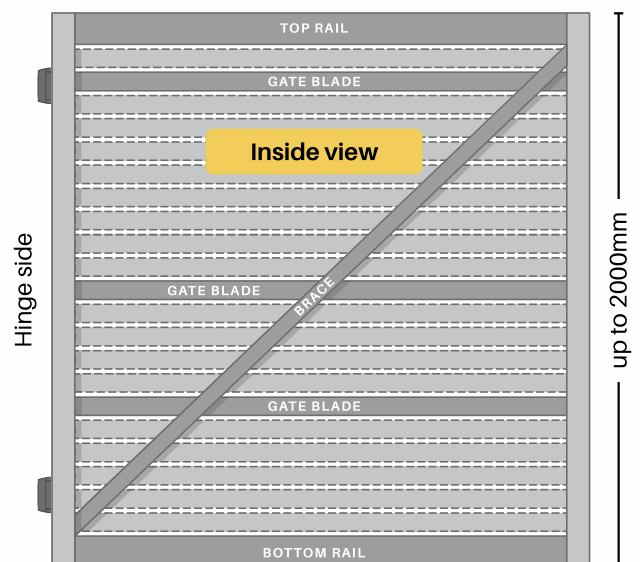

Gate blades:

- 1x 2nd slat down
- 1x middle
- 1x mid-point between middle and bottom

Top/bottom rail:

- 1x heavy duty top rail
- 1x heavy duty bottom rail

Brace:

- 1x centre support rail (Diagonal)

Coming soon!

Patented non-weld lock box

Stay tuned for more info!

Gate assembly

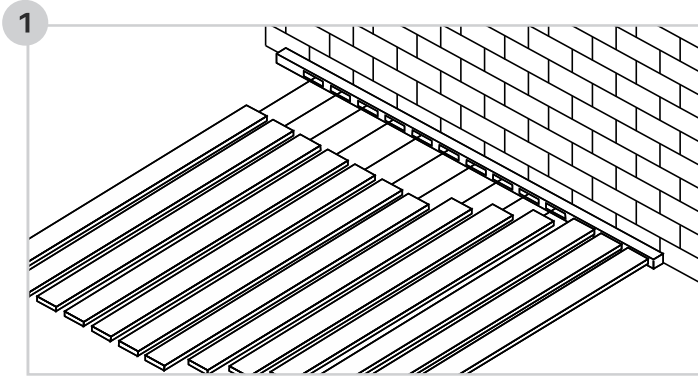

On a flat protected surface, lay 1x gate side frame with slotted spacer infill and rest against a padded stop and tap slats and gate blades into place

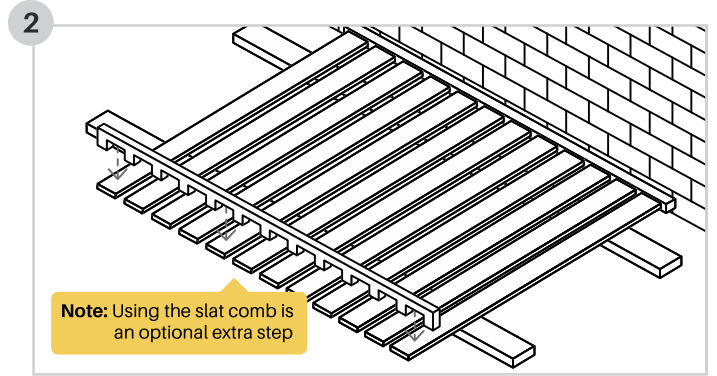

Note: Using the slat comb is an optional extra step

Elevate the slats and gate side frame on two padded bearers to allow the second gate side frame to be attached
Place the slat comb between all slats to prevent any movement of slats in the next step

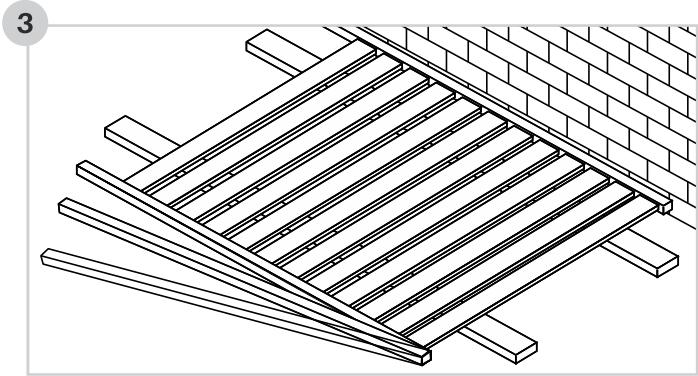

Engage the second gate side frame to the slats and tap the frame until all the slats are fully engaged

TIP: Start at one end and work slats in from one end to the other

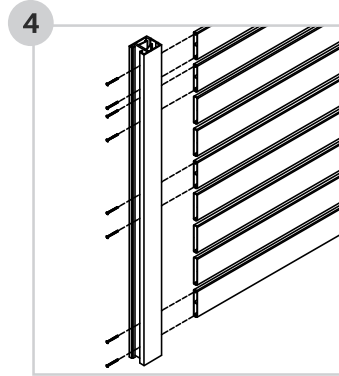

Screw off gate blades at required positions. Ensure gate is square by measuring diagonals

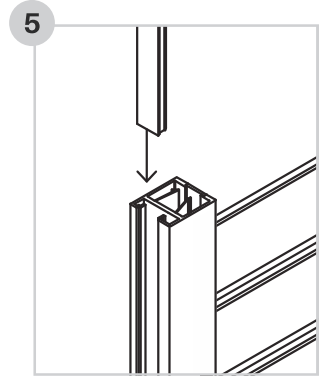

Slide the 2x outer infills down into position to hide screw heads

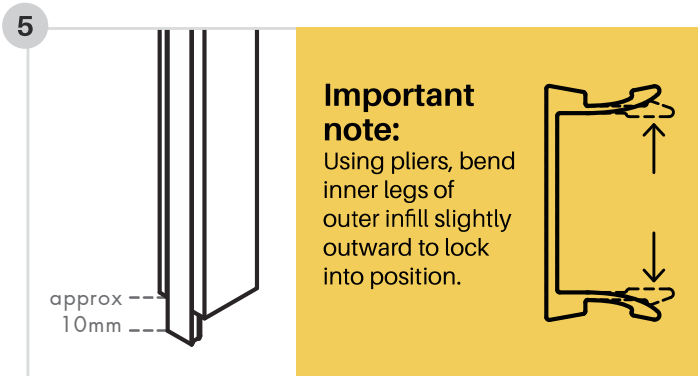

Important note:

Using pliers, bend inner legs of outer infill slightly outward to lock into position.

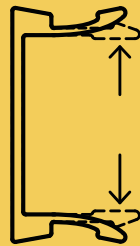

approx
10mm

Slide 2x outer infills past end of gate side frame (approx. 10mm), then using pliers, bend inner legs of outer infill slightly outwards. Tap outer infill back to level with gate side frame

This step is required to stop the outer infill from sliding down prior to hardware installation

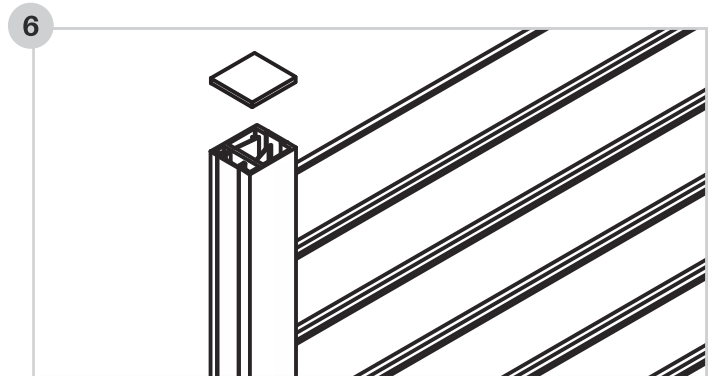

Insert top caps into side frames

To determine the actual slat width for your gate, make a deduction of 36mm to the overall gate width (outer edge to outer edge of gate side frame)

FORMULA: **OVERALL GATE WIDTH - 36MM**
for slat width

You need to allow for hinge and latch gaps

Check hinge and latch hardware specifications for gaps required and take this information into account when determining overall gate width

Screening spacings

Xpresscreens 9mm spacing

Xpresscreens 20mm spacing

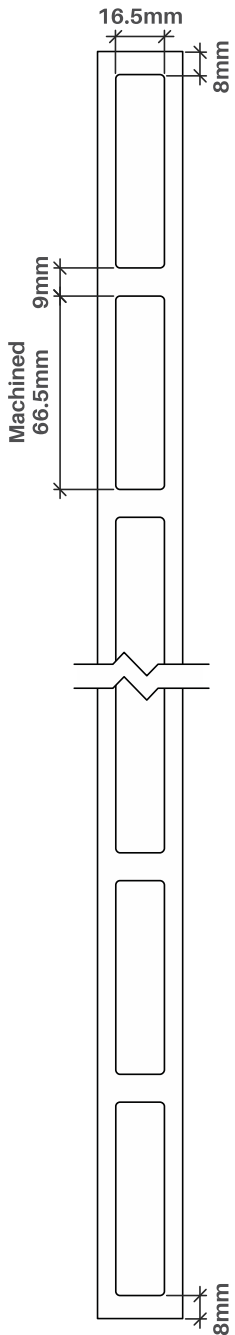

Height	# Blades
309mm	4
384mm	5
458mm	6
533mm	7
607mm	8
682mm	9
756mm	10
831mm	11
905mm	12
980mm	13
1054mm	14
1129mm	15
1203mm	16
1278mm	17
1352mm	18
1427mm	19
1501mm	20
1576mm	21
1650mm	22
1725mm	23
1799mm	24
1874mm	25
1948mm	26
2023mm	27
2097mm	28
2172mm	29
2246mm	30
2321mm	31
2395mm	32
2470mm	33
2544mm	34
2619mm	35
2693mm	36
2768mm	37
2842mm	38
2917mm	39
2991mm	40
3066mm	41
3140mm	42

*Advised heights include 3mm thick top cap

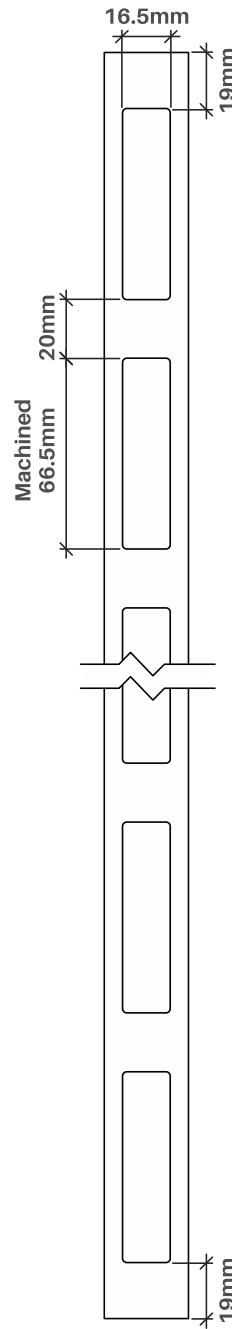

Height	# Blades
369mm	4
456mm	5
542mm	6
629mm	7
715mm	8
802mm	9
888mm	10
975mm	11
1061mm	12
1148mm	13
1234mm	14
1321mm	15
1407mm	16
1494mm	17
1580mm	18
1667mm	19
1753mm	20
1840mm	21
1926mm	22
2013mm	23
2099mm	24
2186mm	25
2272mm	26
2359mm	27
2445mm	28
2532mm	29
2618mm	30
2705mm	31
2791mm	32
2878mm	33
2964mm	34
3051mm	35
3137mm	36
3224mm	37
3310mm	38
3397mm	39
3483mm	40
3570mm	41
3656mm	42

*Advised heights include 3mm thick top cap

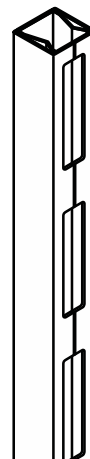
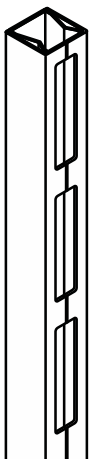

Screening spacings

The Quickscreen & Alumawood side frames allow for variable gap spacing as each slat is fixed off at desired position. Any gap is achievable. Below are specifications for the popular spacings of 9mm and 20mm.

The formula to calculate variable gap screen height is: $((65\text{mm (slat height)} + \text{desired gap}) \times \text{number of slats}) - \text{desired gap} + 3\text{mm (for top cap)}$

For example, a 30mm desired gap with 14 slats: $(65 + 30) \times 14 - 30 + 3 = 1303\text{mm high}$

Quickscreen & Alumawood 9mm spacing

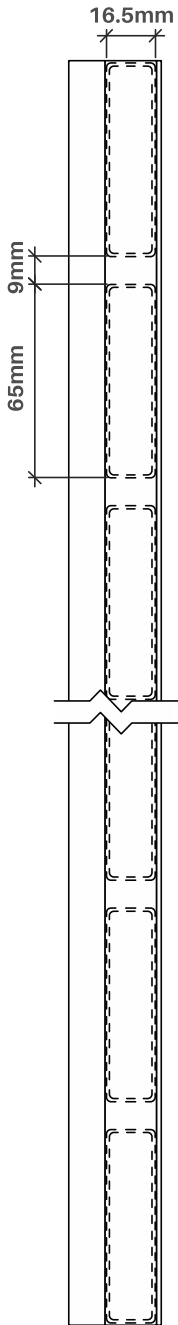

Height	# Blades
290mm	4
364mm	5
438mm	6
512mm	7
586mm	8
660mm	9
734mm	10
808mm	11
882mm	12
956mm	13
1030mm	14
1104mm	15
1178mm	16
1252mm	17
1326mm	18
1400mm	19
1474mm	20
1548mm	21
1622mm	22
1696mm	23
1770mm	24
1844mm	25
1918mm	26
1992mm	27
2066mm	28
2140mm	29
2214mm	30
2288mm	31
2362mm	32
2436mm	33
2510mm	34
2584mm	35
2658mm	36
2732mm	37
2806mm	38
2880mm	39
2954mm	40
3028mm	41
3102mm	42

*Advised heights include 3mm thick top cap

Quickscreen & Alumawood 20mm spacing

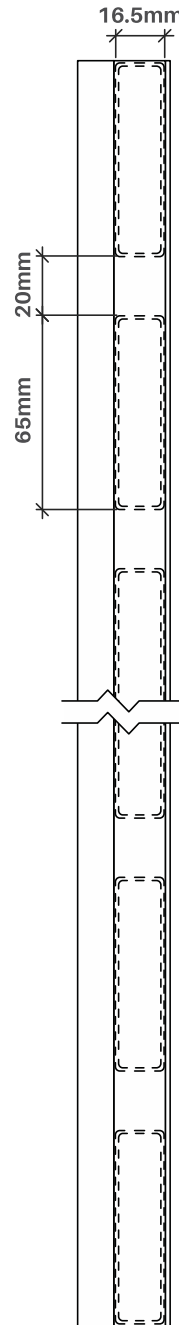

Height	# Blades
323mm	4
408mm	5
493mm	6
578mm	7
663mm	8
748mm	9
833mm	10
918mm	11
1003mm	12
1088mm	13
1173mm	14
1258mm	15
1343mm	16
1428mm	17
1513mm	18
1598mm	19
1683mm	20
1768mm	21
1853mm	22
1938mm	23
2023mm	24
2108mm	25
2193mm	26
2278mm	27
2363mm	28
2448mm	29
2533mm	30
2618mm	31
2703mm	32
2788mm	33
2873mm	34
2958mm	35
3043mm	36
3128mm	37
3213mm	38
3298mm	39
3383mm	40
3468mm	41
3553mm	42

*Advised heights include 3mm thick top cap

Gate screening spacings

Xpresscreens & Quickscreen gates with **9mm spacing**

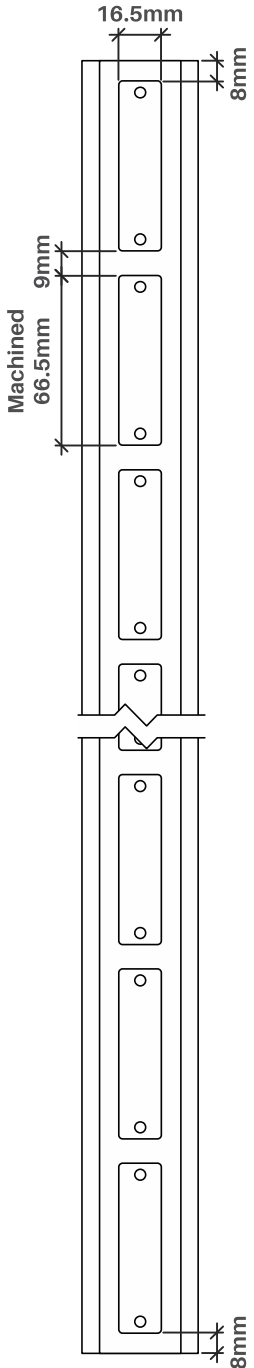

Height	# Blades
309mm	4
384mm	5
458mm	6
533mm	7
607mm	8
682mm	9
756mm	10
831mm	11
905mm	12
980mm	13
1054mm	14
1129mm	15
1203mm	16
1278mm	17
1352mm	18
1427mm	19
1501mm	20
1576mm	21
1650mm	22
1725mm	23
1799mm	24
1874mm	25
1948mm	26
2023mm	27
2097mm	28

* Advised heights include 3mm thick top cap

Gate side frames come with precision drilled holes along the entire extrusion length so gate blade can be affixed at any position

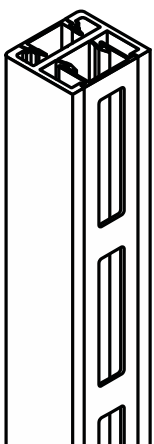

Xpresscreens & Quickscreen gates with **20mm spacing**

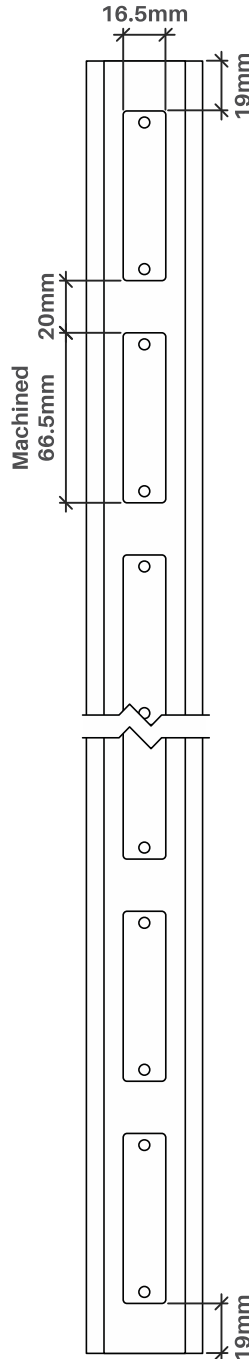

Height	# Blades
369	4
456	5
542	6
629	7
715	8
802	9
888	10
975	11
1061	12
1148	13
1234	14
1321	15
1407	16
1494	17
1580	18
1667	19
1753	20
1840	21
1926	22
2013	23
2099	24

* Advised heights include 3mm thick top cap

Gate side frames come with precision drilled holes along the entire extrusion length so gate blade can be affixed at any position

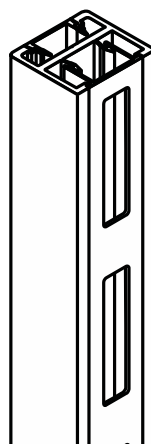

Mounting arm specifications

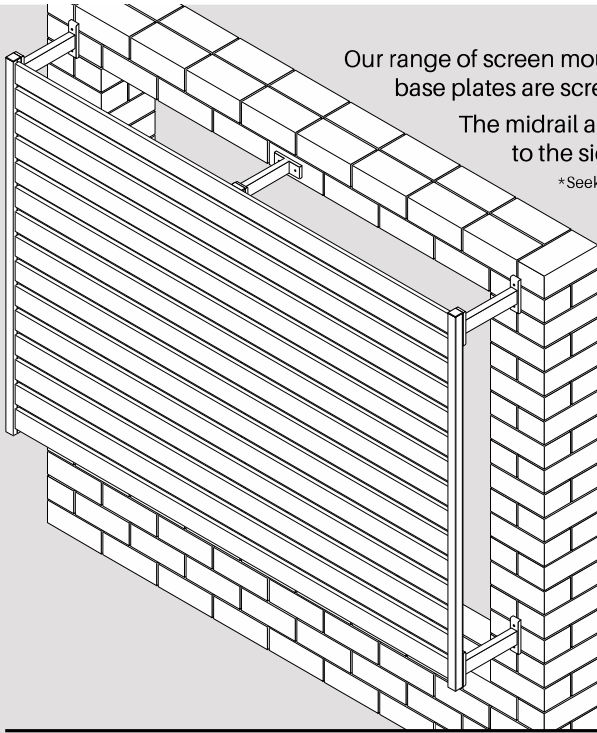

Our range of screen mounting arms are available in mill finish and powder coated finishes. The base plates are screwed into a sturdy 40x20mm extrusion and welded for extra strength.

The midrail arm is slightly shorter due to the centre support rail being a different size to the side frame.

*Seek independent engineering advice as to suitability of arms as each installation is location specific

*Wall fixing plate for centre support rail is rotated horizontally for ease of installation. A vertically positioned wall plate is often inconvenient as the bottom section of base plate may hang into the opening

Mounting arm detail

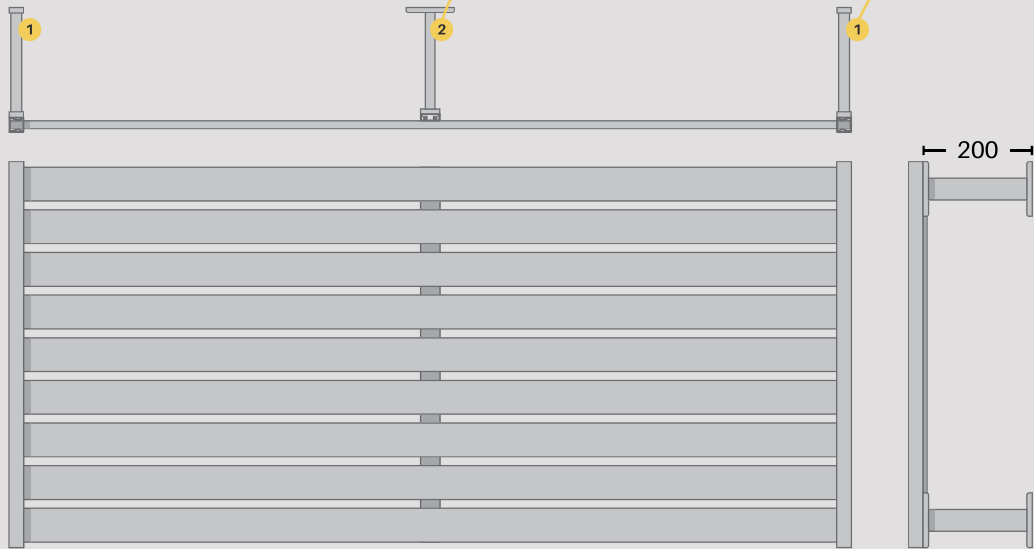
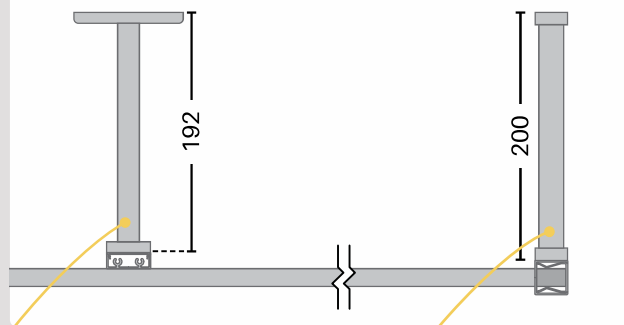

1 Side frame mounting arm

Aluminium - Welded
Colours: B, G, M, S, SM, MN
Order Code: [XP-ARMSF](#)

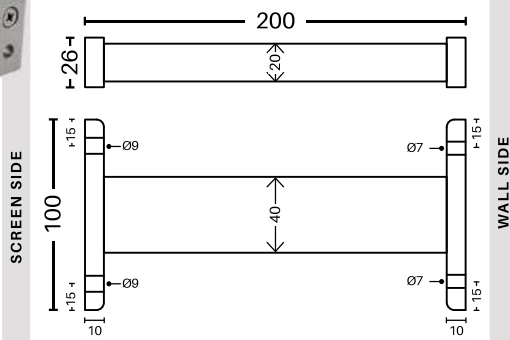

2 Centre support rail mounting arm

Aluminium - Welded
Colours: B, G, M, S, SM, MN
Order Code: [XP-ARMCSR](#)

Must be used with Xpresscreen centre support rail

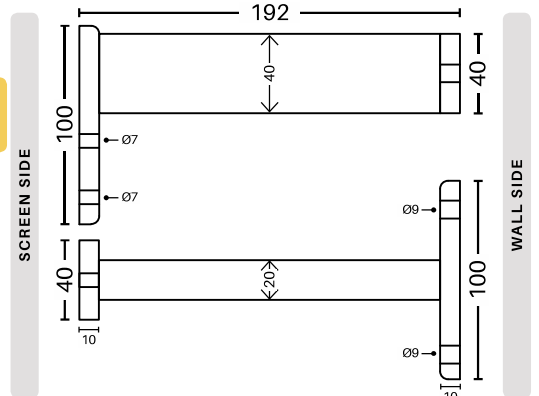

POST INSTALL OVERVIEW



1 Determine fence layout



2 Determine how posts are to be installed:

1. Core drill into concrete (recommended min. Ø76mm core hole at approx. 100mm deep)

2. Base plated to surface (base plates can be screw fixed to posts)

3. Set into ground with concrete footings (recommended footings min 600mm deep x 300mm wide with post embedded to 600mm minimum and then concrete filled)

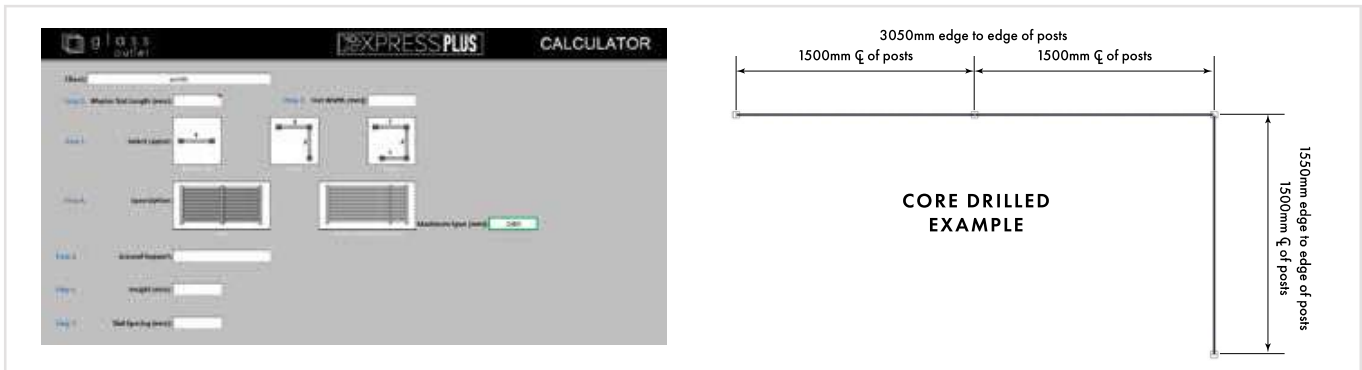

3 Determine post positions

For simplicity, calculate post positions from centre of post to centre of post. Refer Xpress Plus calculator which provides post centres depending on layout selected.

*Recommended that post centres do not exceed 2500mm. In areas of high wind, consider restricting span widths.

Install tip: For end or corner posts of a run, there will be 25mm extra to take into account for 'overhang' of 50mm post.

For base plated installs, end or corner posts have an extra 50mm 'overhang' with the post and base plate.

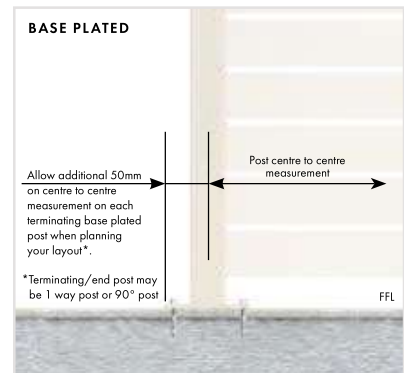
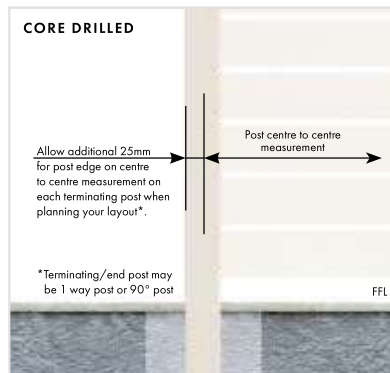

POST INSTALL OVERVIEW

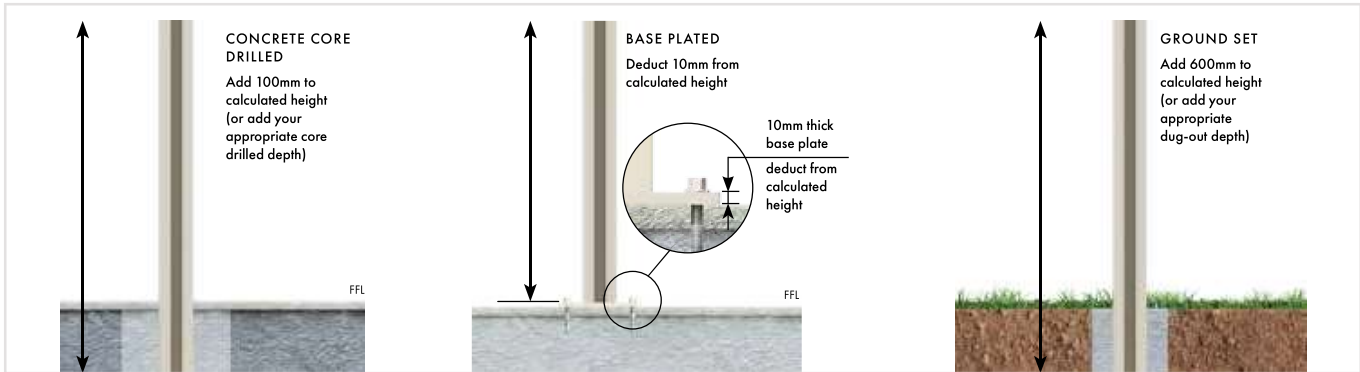

4 Determine overall post height required

The Xpress Plus excel calculator calculates requirements from ground level upwards.

For overall post heights required, add the extra length below the surface for core drill and concrete footings.

For base plated installations, deduct 10mm from screen height (as base plate is 10mm thick)

Install posts.

TIP - Use spirit level to ensure posts are vertically level. Ensure top of posts level and in alignment.

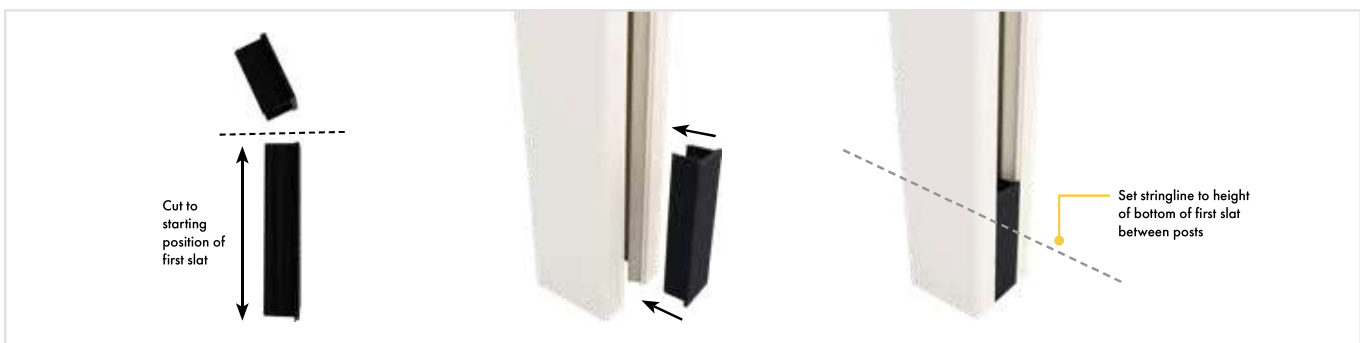

5 Xpress Plus calculator provides calculation of height to cut initial height setting blocks.

NOTE: For uneven ground/deck, cut one setting block only and place at the highest point of the finished floor line. Then, run a level string line to determine heights of remaining setting blocks before cutting to size.

TIP - it is recommended that the bottom gap is no higher than 50mm. Consider lowering or raising overall post height to achieve a starting gap less than 50mm.

Cut setting blocks to suit stringline level and snap into posts.

Use stringline to set first slat height.

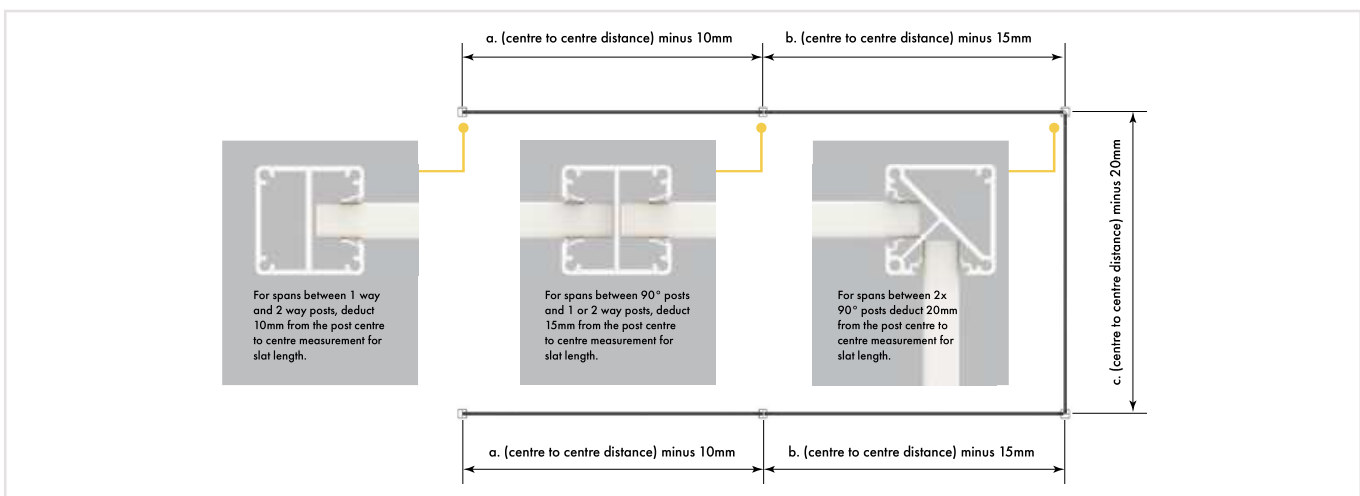

6 Cut slats to appropriate length for each post opening - Refer Xpress Plus excel calculator for guide on slat lengths required.

Deduction summary:

a. For spans between any 1 way post and 2 way post combination, slats are cut **10mm less** than the centre to centre of posts

b. For spans leading into a 90 degree post, slats are cut **15mm less** than the centre to centre of posts

c. For spans between two 90 degree posts, slats are cut **20mm less** than the centre to centre of posts

POST INSTALL OVERVIEW

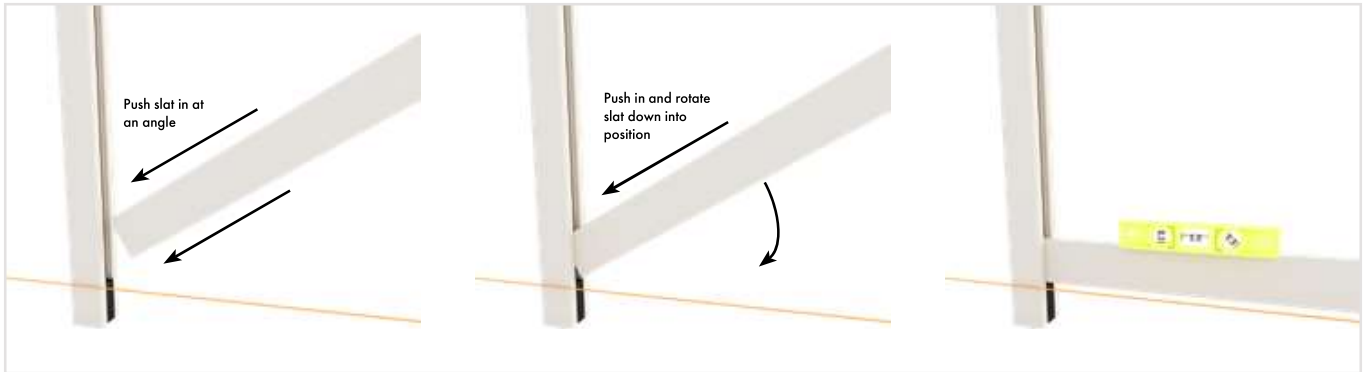

- 7 Install first slat in each span. Using spirit level, ensure slats are level.



- 8 Snap in spacer block above first slat into either side of pocket of post. Repeat for all slats.



- 9 Top slat finishes 5mm below the top of the post. Screw slat locking clip into top slat.

POST INSTALL OVERVIEW



- 10 Install 3mm thick top plate. Use rubber mallet to tap into position.

**OPTIONAL
EXTRA:**

**Centre
support
rail**

See page 46 for full
specifications



- 11 **Install note:** for spans over 2000mm (or in high wind areas under 2000mm wide) it is recommended to have a centre support rail
Place centre support rail against slats and screw off at each slat using XP-SCREWS. Snap on fixing cover to hide screws.



BEFORE YOU START:

1. Inspect working space and ensure there is appropriate area and ground for anchoring
2. Unpack and ensure you have all parts listed on the "Materials list"
3. Remove plastic from parts as needed.

TOOLS REQUIRED:

- Drill + 5mm drill bit
- Phillips head drill bit
- Hammer drill
- 10mm masonry bit
- Flat head screw driver
- Spirit level

MATERIALS LIST: U SHAPE CONFIGURATION

- 48 x Aluminium slats
- 2 x '1 way' aluminium posts
- 2 x 90° aluminium posts
- 4 x Aluminium foot stakes
- 6 x Aluminium snap on fixings cover
- 4 x Black top cap
- 6 x Black U channel top cap
- 20 x Plastic spacer blocks
- 110 x Self-tapping screws

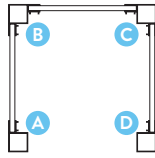

MATERIALS LIST: L SHAPE CONFIGURATION

- 32 x Aluminium slats
- 1 x '1 way' aluminium posts
- 1 x 90° aluminium posts
- 2 x Aluminium foot stakes
- 4 x Aluminium snap on fixings cover
- 1 x Aluminium U Channel
- 2 x Black top cap
- 4 x Black U channel top cap
- 20 x Plastic spacer blocks
- 80 x Self-tapping screws

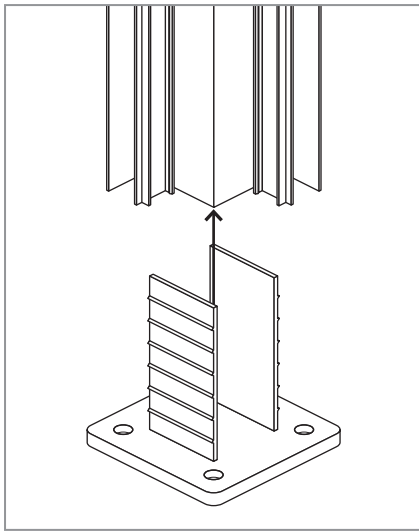
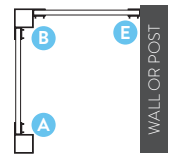

1. Insert foot stakes into post

Tip: Lay out posts where they will be installed to ensure foot stakes are inserted in correct position

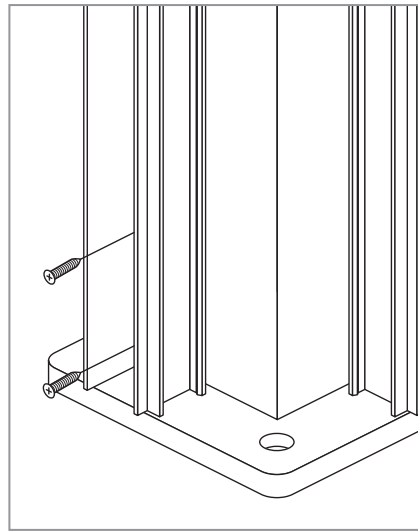

2. With supplied self-tapping screws, screw through the 2x pre-drilled holes in post to secure foot stake into position
Note: ONLY ONE SIDE of foot stake requires securing - secure the side where the vertical wall of the foot stake receives the 2x screws

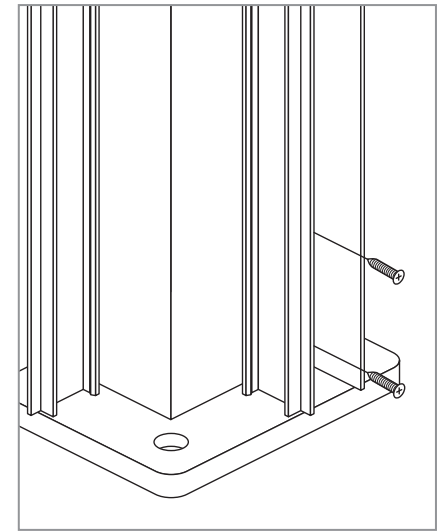

3. Repeat steps 1 and 2 with all remaining posts

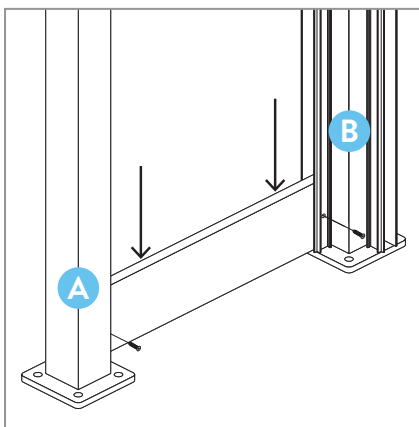

4. Insert from top 1x slat and lower down so it rests on top of foot stake for A & B. Use spirit level to ensure level. With self tapping screw, drill through 'u channel' wall of A & B at mid-point of slat

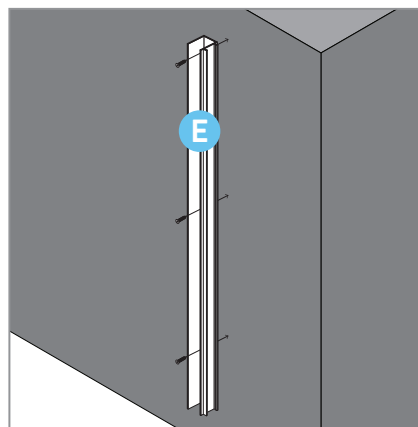

5 (a). Applies to "L Shape" config. only Affix U Channel to wall or existing post with suitable fixings. If affixing to an aluminium post, the supplied screws are suitable. If affixing to timber, concrete or steel, install using suitable fixings (not supplied)

Tip: Top of U channel should line up with top of adjacent post

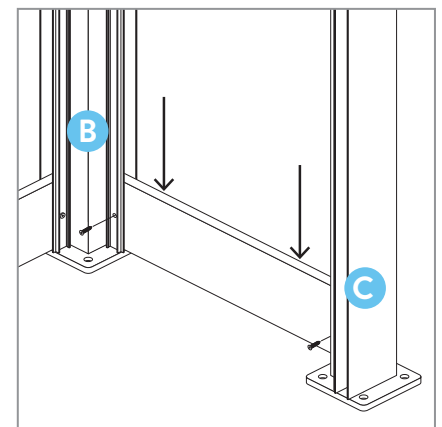

5 (b). Repeat step 4
For 'U shape config.': 1x slat installed from B to C
For "L shape config.": 1x slat installed from B to E
For L shape, go to step 7

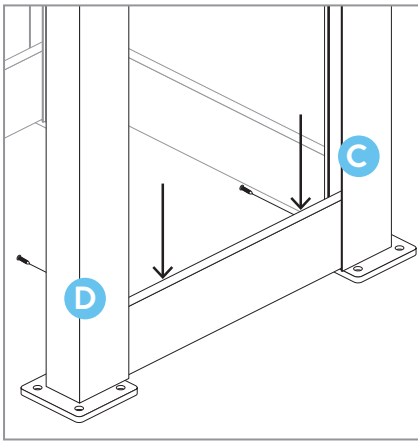

6. Applies to "U Shape" config. only
Install 1x slat from C to D. You should now have 3x bottom slats secured completing the first level of the U shape

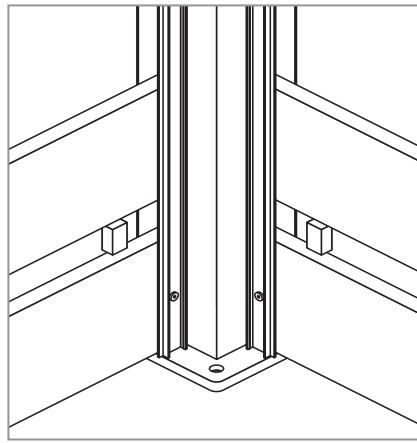

7. Spacer blocks are provided to assist with achieving perfect slat spacing. The system is designed for 9mm spacing to achieve a neat finish at top of post, however, any spacing can be achieved but consider final top slat position

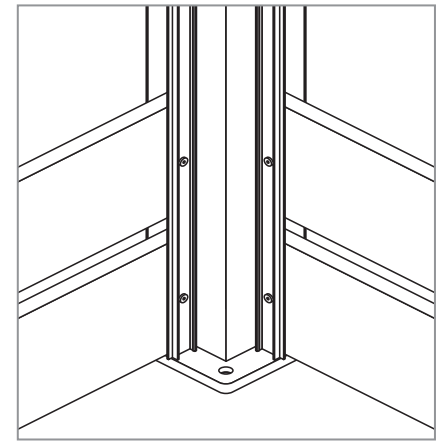

8. Lower in slats from top down and screw off slats. Build one complete layer at a time to ensure slats line up per level. Once each layer is built, remove spacer blocks from between slats

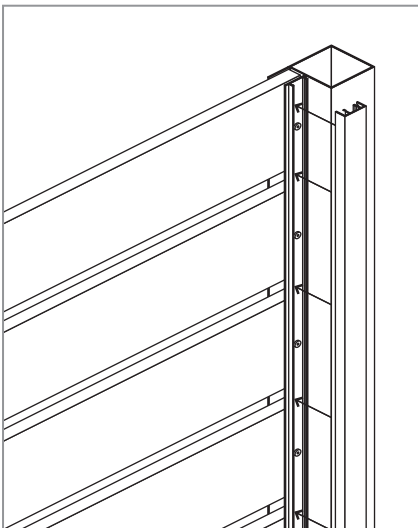

9. Clip on fixing cover to hide all screws. Repeat for all posts where screws are visible

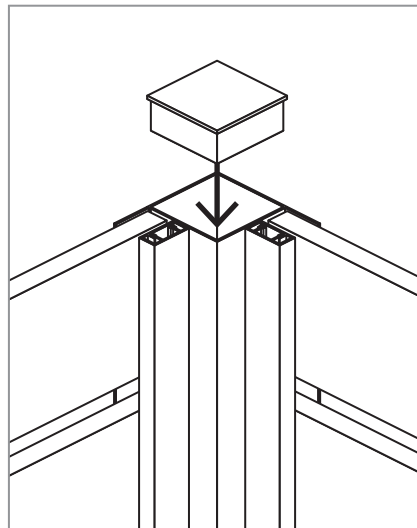

10. Tap in 50mm post top caps. Repeat for all posts

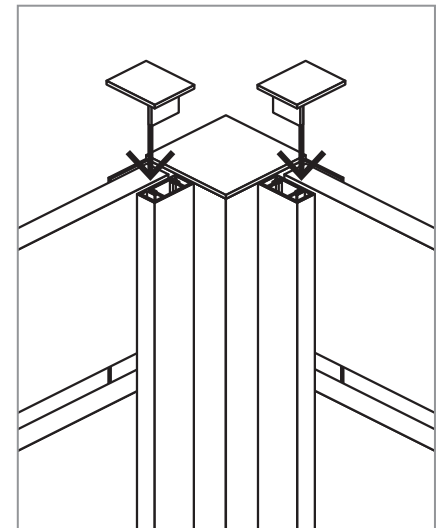

11. Tap in smaller channel caps. Repeat for all channels

U Shape Configuration

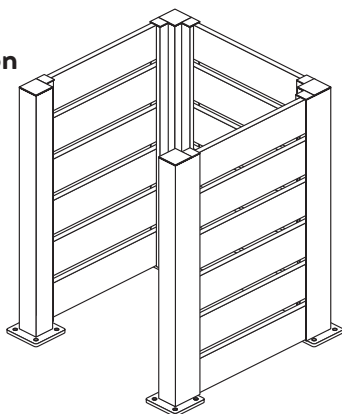

OR

L Shape Configuration

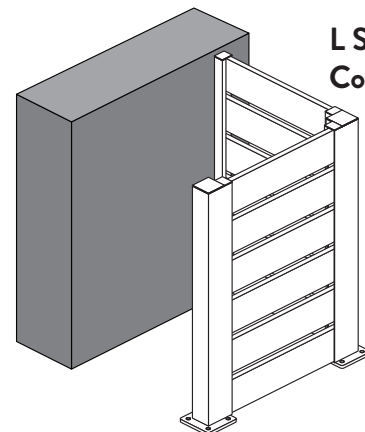

12. Drill/bolt foot stakes to ground with suitable fixings (not included). Ensure secured appropriately and stable

IMPORTANT NOTE: Drawings in this install guide are not to scale. Height of posts and number of slats shown are representations only and will differ from actual product