

BLITZ GLASS

XPRESS

**Screening &
Gate System**



www.blitzglass.com.au



(07) 5493 9779



admin@blitzglass.com.au



CENTRE WEB
ADDS STRENGTH &
RIGIDITY TO SLAT

65mm x 16.5mm slat with centre web 6100MM LONG

Order Code: **XP-6100-S65**

SOLD AS SINGLE LENGTHS,
BUNDLES OR PACK LOTS

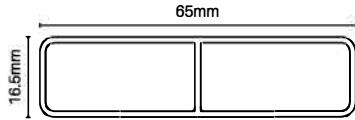

Finishes —



TECH SPECS

- PP 157 / AP 157
- Alloy 6063-T6
- 6100mm long
- 1.2mm wall thickness with centre web
- 3.5mm radius corners
- Genuine Australian Interpon powder coat
- lxx = 9.60 x 10E3 mmE4
- lyy = 83.09 x 10E3 mmE4

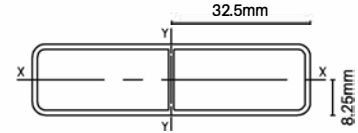

BUY IN PACK LOTS
FOR BEST PRICING!

65mm x 16.5mm slat 6500MM LONG

Order Code: **XP-6500-E65**

SOLD IN PACKS OF 96 ONLY
Not sold as single lengths

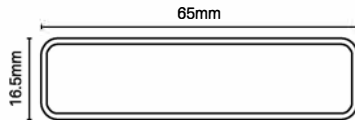

Finishes —



TECH SPECS

- PP 157 / AP 157
- Alloy 6063-T6
- 6500mm long
- 1.2mm wall thickness
- 3.5mm radius corners
- Genuine Australian Interpon powder coat
- lxx = 9.31 x 10E3 mmE4
- lyy = 83.09 x 10E3 mmE4

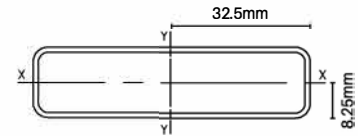

CENTRE WEB
ADDS STRENGTH &
RIGIDITY TO SLAT

90mm x 16.5mm slat with centre web 6100MM LONG

Order Code: **QS-6100-S90**

SOLD AS SINGLE LENGTHS,
BUNDLES OR PACK LOTS

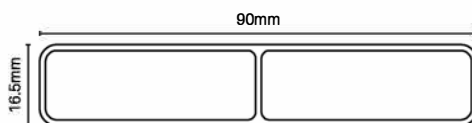

Finishes —



TECH SPECS

- PP 208 / AP 208
- Alloy 6063-T6
- 6100mm long
- 1.2mm wall thickness with centre web
- 3mm radius corners
- Genuine Australian Interpon powder coat
- lxx = 13.28 x 10E3 mmE4
- lyy = 202.57 x 10E3 mmE4

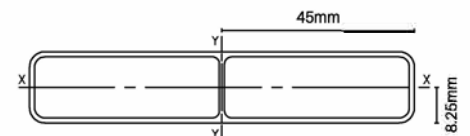



50x50mm full post
2400MM or 6000MM LONG
Order Code: **XP-2400/6000-FP**

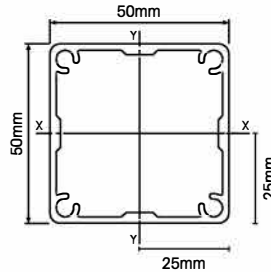

Finishes —



TECH SPECS

- Alloy 6063 - T6
- 1.8mm wall thickness with 3mm ribs
- Screw flutes to screw on base plate if required
- Aluminium powder coated press-in top plate included with 2400mm posts
- $b_{xx} = 170.44 \times 10E3 \text{ mmE4}$
- $b_{yy} = 170.44 \times 10E3 \text{ mmE4}$

4x screw flutes in post allow tight fit of press in flat aluminium top plate.

Optional base plate can be attached using screw flutes for base plated post installations.



65x65mm heavy duty post
2400MM or 6000MM LONG
Order Code: **XP-2400/6000-65HD**

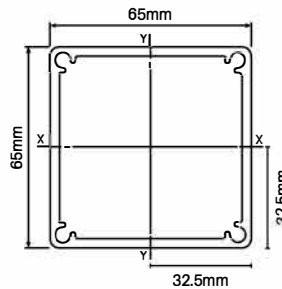

Finishes —



TECH SPECS

- 65x65mm larger profile, heavy duty post
- Alloy 6063 - T6
- 3mm wall thickness
- Screw flutes to screw on base plate if required
- Aluminium powder coated press-in top plate included with 2400mm posts
- $b_{xx} = 464.62 \times 10E3 \text{ mmE4}$
- $b_{yy} = 464.62 \times 10E3 \text{ mmE4}$

4x screw flutes in post allow tight fit of press in flat aluminium top plate.

Optional base plate can be attached using screw flutes for base plated post installations.



50x50mm post flat top plate
POWDER COATED ALUMINIUM
Black / Monument / Woodland grey / Silver / Surfmist
White / Basalt / Dune / Mill finish
Order Code: **XP-TP**

- Alloy ADC12 aluminium plate
- Press into post screw flutes for secure fixing
- 2400mm posts come with free top plate included - only purchase if extra top plates are required
- Top plates required for 6000mm posts - sold separately



65x65mm post flat top plate
POWDER COATED ALUMINIUM
Black / Monument / Woodland grey / Silver / Surfmist
White / Basalt / Dune / Mill finish
Order Code: **XP-65TP**

- Alloy ADC12 aluminium plate
- Press into post screw flutes for secure fixing
- 2400mm posts come with free top plate included - only purchase if extra top plates are required
- Top plates required for 6000mm posts - sold separately

SUITS 50x50MM POSTS

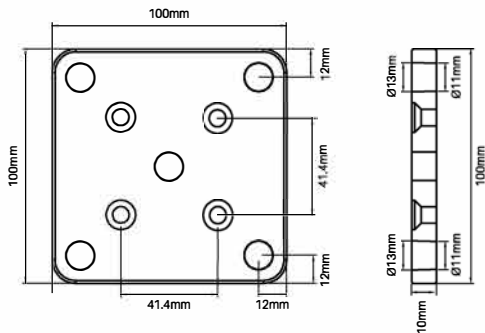

50x50mm post base plate set
 POWDER COATED ALUMINIUM
Black / Monument / Woodland grey
Silver / Surfmist / White / Basalt
Dune / Mill finish

Order Code: **XP-BP-SET**

- Simply screw base plate onto core drill post
- 4x 12G x 50mm long CSK screws included in set

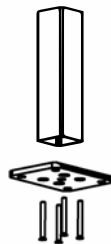

Powder coat colours —



SUITS 65x65MM POSTS

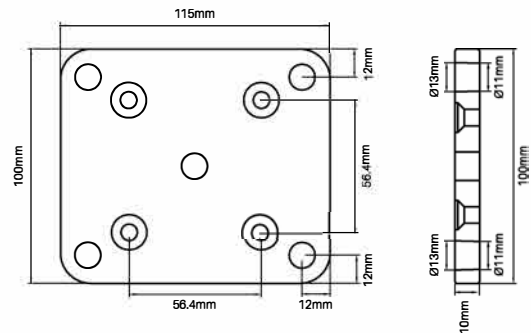

65x65mm post base plate set
 POWDER COATED ALUMINIUM
Black / Monument / Woodland grey
Silver / Surfmist / White / Basalt
Dune / Mill finish

Order Code: **XP-65BP-SET**

- Simply screw base plate onto core drill post
- 4x 12G x 50mm long CSK screws included in set

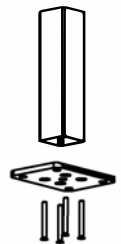

Powder coat colours —



Discreet screws fix two parts of cover together

50x50mm Two part domical cover

POWDER COATED ALUMINIUM
Black / Monument / Woodland grey
Silver / Surfmist / White / Basalt
Dune / Mill finish

Order Code: **XP-DC-2P**

- Suits 50x50mm post with screw fixed base plate
- 106x106mm outer - 52x52mm inner - Alloy ADC12
- Cover can be fitted to posts after fence is installed



50x50mm post dress ring

POWDER COATED ALUMINIUM
Black / Monument / Woodland grey
Silver / Surfmist / White / Basalt
Dune / Mill finish

Order Code: **XP-DR**

- Suits 50x50mm core drill posts
- 100mm x 100mm outer - 52mm x 52mm inner

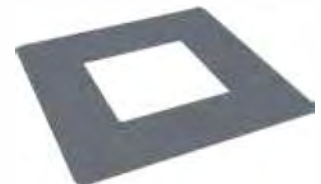

65x65mm post dress ring

POWDER COATED ALUMINIUM
Black / Monument / Woodland grey
Silver / Surfmist / White / Basalt
Dune / Mill finish

Order Code: **XP-65DR**

- Suits 65x65mm heavy duty post
- 115mm x 115mm outer - 67mm x 67mm inner



U channel 6000MM LONG

Order Code: **XPL-6000-U**

OPTIONAL EXTRA
See page 46 - only required for 'method 2' assembly

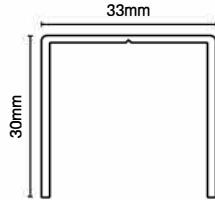

TECH SPECS

- PP 181 / AP 181
- Alloy 6063-T5
- 6000mm long
- 1.55mm side wall thickness; 1.3mm rear wall thickness
- $b_{xx} = 12.46 \times 10E3 \text{ mmE4}$
- $b_{yy} = 25.09 \times 10E3 \text{ mmE4}$

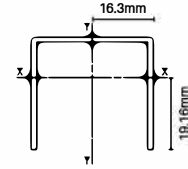

Finishes —



F section 6000MM LONG

Order Code: **XPL-6000-F**

OPTIONAL EXTRA
See page 46 - only required for 'method 2' assembly

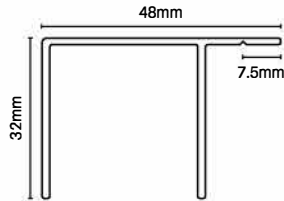

TECH SPECS

- PP 146 / AP 219
- Alloy 6060-T5
- 6000mm long
- 1.55mm side wall thickness; 1.3mm rear wall thickness
- Useful when installing in void situations
- $b_{xx} = 16.97 \times 10E3 \text{ mmE4}$
- $b_{yy} = 36.45 \times 10E3 \text{ mmE4}$

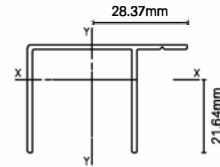

Finishes —



Centre support rail 5800MM LONG

Order Code: **XP-5800-CSR**

OPTIONAL EXTRA
Commonly used for screens 2000mm or wider to provide strength & rigidity to panel
Snap-on cover hides fixings - provides slimline sturdy support rail with no visible fixings

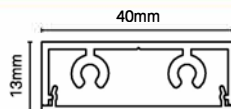

TECH SPECS

- PP 126 / AP 188
- Alloy 6063-T5
- 5800mm long
- Includes 2x screw flutes for cap insertion
- $b_{xx} = 1.73 \times 10E3 \text{ mmE4}$
- $b_{yy} = 26.34 \times 10E3 \text{ mmE4}$

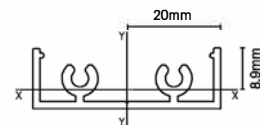

Finishes —





50 PACK
Spacer block
5MM SPACING

Order Code: **XPL-SB-50PK-05MM**

- UV stabilised ASA thermoplastic - black
- Snaps into Xpress Plus side frame
- Provides 5mm space between slats
- Fast and easy install with side frame, slats and spacers



50 PACK
Spacer block
9MM SPACING

Order Code: **XPL-SB-50PK-09MM**

- UV stabilised ASA thermoplastic - black
- Snaps into Xpress Plus side frame
- Provides 9mm space between slats
- Fast and easy install with side frame, slats and spacers



50 PACK
Spacer block
20MM SPACING

Order Code: **XPL-SB-50PK-20MM**

- UV stabilised ASA thermoplastic - black
- Snaps into Xpress Plus side frame
- Provides 20mm space between slats
- Fast and easy install with side frame, slats and spacers



5 PACK
Block
100MM LONG

Order Code: **XPL-BLOCK-5PK**

- UV stabilised ABS - black
- Snaps into Xpress Plus side frame
- 100mm long - can be easily cut to any spacer size
- Ideal for custom slat spacing



Louvre brackets
1x LEFT & 1x RIGHT
Black / Monument / Woodland grey / Silver / Surfmist / White Basalt / Dune / Mill finish

Order Code: **QS-LB**

- 1x left and 1x right bracket per pack
- Die cast aluminium
- Suits 65x16.5mm slat - Press brackets onto end of slat then insert bracket into side frame
- Space brackets at nill, 5, 9, 20mm or any spacing desired
- Cost effective and fast way to achieve a fixed louvre finish

40° FINAL SLAT ANGLE

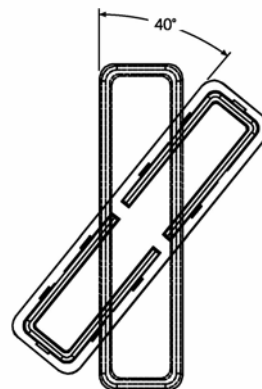

10 PACK
Slat locking clip

Order Code: **XPL-SLATCLIP-10PK**

- Aluminium cast locking clip with SS304 self tapping screws
- Optional extra for install. Acts as mechanical fix to prevent chance of side frames splaying open. Consider if installing side frames to timber posts which may move/twist OR if side frames installed onto aluminium posts for large fence runs - Generally not required for side frame installs to pillars
- Hidden under side frame end plate



Self drilling wafer screws
10Gx16mm - BAG OF 100
Black / Monument / Woodland grey / Silver / Surfmist / White Basalt / Dune / Mill finish

Order Code: **XP-SCREWS**

- Bags of 100 - 10G x 16mm self drilling wafer head zinc plated
- Powder coated heads for neat finish
- Ideal for fixing of side frames to U channel or F section



Touch up paint
150g SPRAY CAN
Black / Monument / Woodland grey / Silver / Surfmist / White Basalt / Dune

Order Code:
PAINT-BLACK/G/MN/SILVER/SM/W/BS/D

- Colour match touch up paint
- Simply spray on for minor touch ups



Side frame

28mm x 32mm

6000MM LONG

Order Code: **XPL-6000-SF**

PATENTED FRICTION FIT SYSTEM

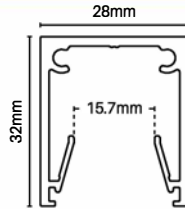

TECH SPECS

- PP 120 / AP 246
- Alloy 6060-T5
- 6000mm long
- 2x screw flutes in extrusion used for mechanical fixing of end plates
- Slats are held by patented friction legs - no screwing, riveting or welding required
- $l_{bx} = 21.49 \times 10E3 \text{ mmE4}$
- $l_{ly} = 25.27 \times 10E3 \text{ mmE4}$

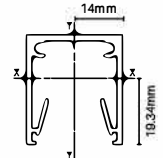

Finishes —

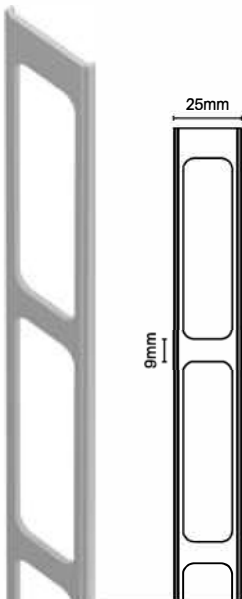

9MM SPACING

Aluminium insert

2100MM LONG

Order Code: **XPL-2100-INS09**

OPTIONAL EXTRA

Slide into Xpress Plus side frame for premium 9mm spacing finish

How to use:

1. Screw fix 1x end plate to bottom of side frame
2. Slide aluminium insert into side frame
3. Screw fix 1x end plate to top of side frame
4. Install slats into aluminium insert

TECH SPECS

- PP 55 / AP 55
- Alloy 6063-T6
- 2100mm long
- Specially machined with 9mm spacing to suit 65x16.5mm slat
- $l_{bx} = 0.014 \times 10E3 \text{ mmE4}$
- $l_{ly} = 2.267 \times 10E3 \text{ mmE4}$

Important: To ensure correct function of insert

Before sliding in insert, trim cut side frame both ends to remove any excess build up of powder coat in slide channels

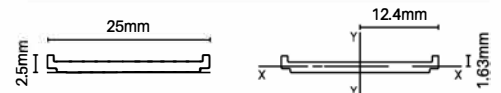

Finishes —

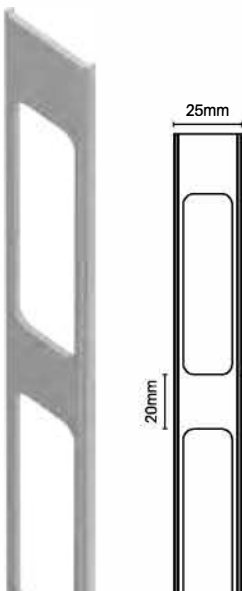

20MM SPACING

Aluminium insert

2100MM LONG

Order Code: **XPL-2100-INS20**

OPTIONAL EXTRA

Slide into Xpress Plus side frame for premium 20mm spacing finish

How to use:

1. Screw fix 1x end plate to bottom of side frame
2. Slide aluminium insert into side frame
3. Screw fix 1x end plate to top of side frame
4. Install slats into aluminium insert

TECH SPECS

- PP 55 / AP 55
- Alloy 6063-T6
- 2100mm long
- Specially machined with 20mm spacing to suit 65x16.5mm slat
- $l_{bx} = 0.014 \times 10E3 \text{ mmE4}$
- $l_{ly} = 2.267 \times 10E3 \text{ mmE4}$

Important: To ensure correct function of insert

Before sliding in insert, trim cut side frame both ends to remove any excess build up of powder coat in slide channels

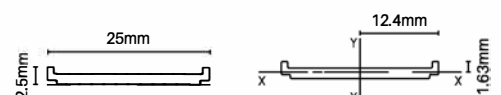

Finishes —



END PLATES & MOUNTING ARMS



2 PACK
Side frame end plate
28mm x 32mm
3MM THICK

Order Code: **XPL-EP-2PK**

MATES WITH XPL-6000-SF

TECH SPECS

- Pack of 2 - affix to top and bottom of side frame
- 3mm thick
- Aluminium end plates fix into screw flute in Xpress Plus side frame
- Countersunk holes & screws provide neat flush fitting
- Mechanically fixed end plates ensure sturdy finish

Finishes —



Centre support rail cap
40mm x 13mm
3MM THICK

Order Code: **XP-CSRC**

- Nylon cap available in 5 colours
- Simply press into screw flutes in centre support rail
- Easy and fast fitting of cap

MATES WITH XP-5800-CSR



Centre support rail top/bottom plate

Order Code: **XP-BTP**

- Aluminium with countersunk hole machining
- Optional extra to install with centre support rail
- Use to brace off top and/or bottom of centre support rail to structure above or below if desired
- Bracing centre support rail provides extra rigidity to panels - recommended for wide screens
- Available in same colours as centre support rail

MATES WITH XP-5800-CSR

Finishes —

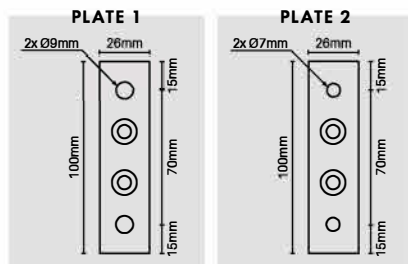
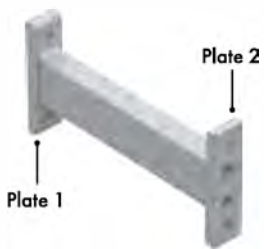
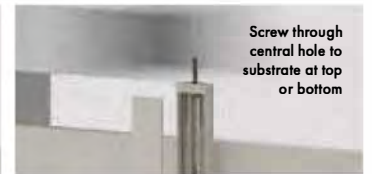

Side frame mounting arm
 200MM or 400MM WIDE
 Black / Monument / Woodland grey
 Silver / Surfmist / Mill finish

Order Code: **XP-ARMSF (200mm W)**
XP-ARMSF-400-M (400mm W - Mill finish)

- 2x welded fixing plates - 100mm L x 26mm W x 10mm D
- 2x Ø9mm fixing holes (plate 1) & 2x 7mm fixing holes (plate 2)

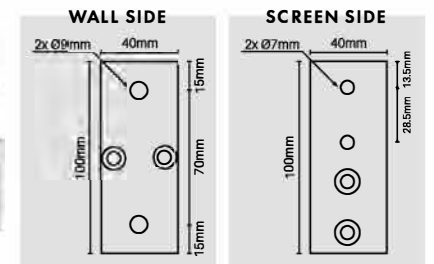
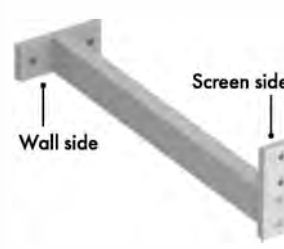
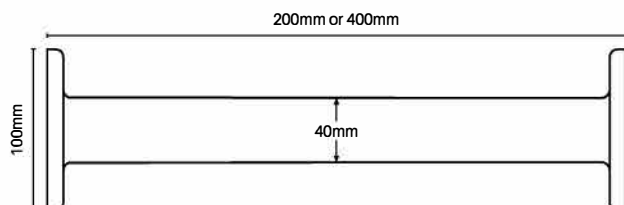

Centre support rail mounting arm
 200MM or 392MM WIDE
 Black / Monument / Woodland grey
 Silver / Surfmist / Mill finish

Order Code: **XP-ARMCSR (200mm W)**
XP-ARMCSR-392-M (392mm W - Mill finish)

- Specially designed shorter arm to match up with centre support rail when installing Xpress Plus side frames with 200mm or 400mm side frame support arms
- Wall side plate rotated horizontally so as to not protrude into window opening

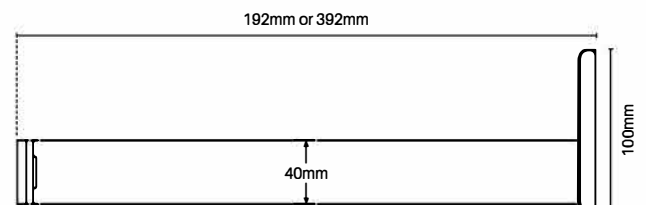

Pedestrian gate options

SELECT FROM A RANGE OF PEDESTRIAN GATE OPTIONS

We can cut to size, flat pack and send Australia wide or you can purchase long length extrusions and cut to size yourself.

Assemble pre-powder coated gates with no welding or riveting required.

Save time and money without requirement of fully fabricating and welding gates.

Contact us for detailed assembly instructions



1 Horizontal slat pedestrian gate

Fitted with D&D LOKK Latch Deluxe

65mm x 16.5mm slats with 9mm or 20mm slat spacing

Patented gate side frames for fast assembly



2 Horizontal slat pedestrian gate

Fitted with D&D LOKK Latch Deluxe

65mm x 16.5mm or 90mm x 16.5mm slats

Variable slat spacing

Each slat required to be screw fixed



3 Horizontal slat pedestrian gate

Fitted with Lockwood 001 deadlatch

65mm x 16.5mm slats with 9mm or 20mm slat spacing

Patented gate side frames for fast assembly

Patented non-weld lockbox



4 Horizontal slat pedestrian gate

Fitted with knob or lever handle

65mm x 16.5mm slats with 9mm or 20mm slat spacing

Patented gate side frames for fast assembly

Patented non-weld lockbox



5 Vertical slat pedestrian gate

Fitted with D&D LOKK Latch Deluxe

65mm x 16.5mm or 90mm x 16.5mm slats

Variable slat spacing

Each slat required to be screw fixed

GATE EXTRUSIONS



PATENTED FRICTION FIT SYSTEM

9MM SPACING Slotted gate side frame

4200MM LONG

Order Code: XP-4200-GSF09

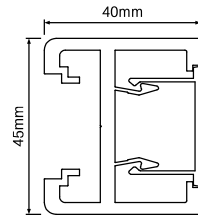

TECH SPECS

- PP 170
- Alloy 6063-T5 / 4200mm long
- 3mm wall thickness with 3.8mm centre crossmember
- Slotted insert to suit 65x16.5mm slat with 9mm spacing
- Patented frame for friction insertion of slats
- Crossmember machined with drill holes along entire length to suit screw fixing of strategically placed 'gate slats' featuring screw flutes
- lxx = 6.294 x 10E3 mmE4
- lyy = 152.403 x 10E3 mmE4

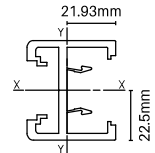

Finishes



PATENTED FRICTION FIT SYSTEM

20MM SPACING Slotted gate side frame

4200MM LONG

Order Code: XP-4200-GSF20

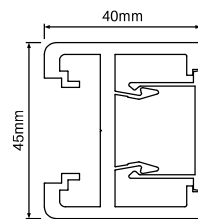

TECH SPECS

- PP 170
- Alloy 6063-T5 / 4200mm long
- 3mm wall thickness with 3.8mm centre crossmember
- Slotted insert to suit 65x16.5mm slat with 20mm spacing
- Patented frame for friction insertion of slats
- Crossmember machined with drill holes along entire length to suit screw fixing of strategically placed 'gate slats' featuring screw flutes
- lxx = 6.294 x 10E3 mmE4
- lyy = 152.403 x 10E3 mmE4

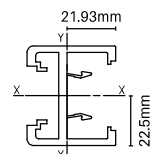

Finishes



Snap-in gate insert

4200MM LONG

Order Code: XP-4200-GI

MATES WITH XP-4200-GSF09/20

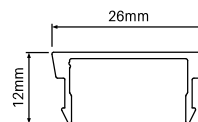

TECH SPECS

- PP 100 / AP 100
- Alloy 6060-T5 / 4200mm long
- Snap-in gate insert mates with gate side frame
- Hides screws required for fixing 'gate slats' into position
- lxx = 0.86 x 10E3 mmE4
- lyy = 5.93 x 10E3 mmE4

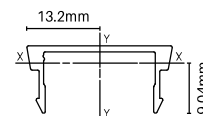

Finishes



GATE EXTRUSIONS



NON-PUNCHED Gate infill

4200MM LONG
Order Code: XP-XBAT-4200-INF

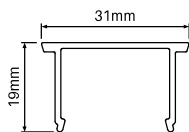

TECH SPECS

- PP 100 / AP 133
- Alloy 6060-T5 / 4200mm long
- Non-punched snap-in infill for gate side frames
- Required when making vertical gates, variable spaced horizontal slat gates or gates using 90mm x 16.5mm slats
- Replace existing slotted infill in gate side frame with non-punched gate infill
- lxx = 2.94 x 10E3 mmE4
- lyy = 9.50 x 10E3 mmE4

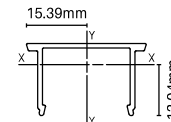

Finishes

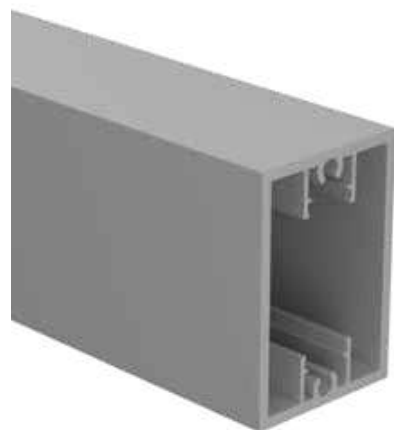

Heavy duty top/bottom rail

6100MM LONG
Order Code: XP-6100-HD6545

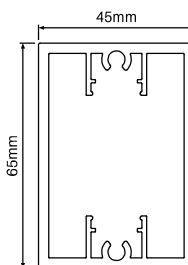

TECH SPECS

- PP 219 / AP 219
- Alloy 6063-T5 / 6100mm long
- 3mm wall thickness
- Heavy duty top/bottom rail used for wide gates
- Also required for vertical slat gates, horizontal gates with variable spacing or gates fitted with a lockbox
- Non weld assembly using 12 gauge screws into screw flutes (Code: XP-SCREWSGF-10PK)
- lxx = 206.98 x 10E3 mmE4
- lyy = 427.32 x 10E3 mmE4

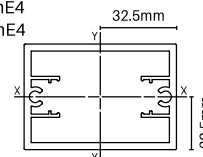

Finishes



65mm x 16.5mm gate slat with centre web & 2x screw flutes

6100MM LONG
Order Code: XP-6100-GB65

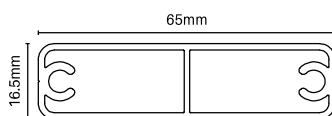

TECH SPECS

- PP 158 / AP 158
- Alloy 6063-T6
- 6100mm long
- 1.5mm wall thickness with 1.2mm wall centre web
- 2x screw flutes
- Used in strategic positions for pedestrian gate assembly
- Non weld assembly using 12 gauge screws into screw flutes (Code: XP-SCREWSGF-10PK)
- lxx = 11.85 x 10E3 mmE4
- lyy = 144.09 x 10E3 mmE4

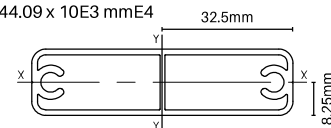

Finishes



STANDARD SLATS ALSO
REQUIRED FOR GATE ASSEMBLY
SEE PAGE 6 FOR SLAT OPTIONS

GATE EXTRUSIONS



Quickscreen side frame

5800MM LONG
Order Code: **QS-5800-SF**

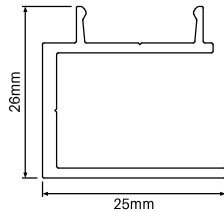

TECH SPECS

- PP 104 / AP 156
- Alloy 6063-T6 / 5800mm long
- Used for gates with horizontal variable slat spacing and vertical slat gates
- Each slat must be screw fixed to side frame
- Affix side frame to 45mm x 40mm gate frame
- $l_{xx} = 9.58 \times 10E3 \text{ mmE4}$
- $l_{yy} = 8.38 \times 10E3 \text{ mmE4}$

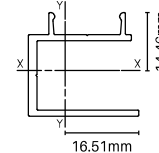

Finishes



Quickscreen concealed fixing cover

5800MM LONG
Order Code: **QS-5800-CFC**

MATES WITH QS-5800-SF

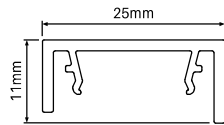

TECH SPECS

- PP 100 / AP 116
- Alloy 6060-T5 / 5800mm long
- Snap-on cover for Quickscreen side frame
- Hides screws used to affix slats to side frame
- $l_{xx} = 0.71 \times 10E3 \text{ mmE4}$
- $l_{yy} = 6.58 \times 10E3 \text{ mmE4}$

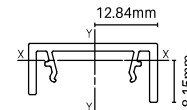

Finishes



Gate stop

4200MM LONG
Order Code: **XP-4200-GSTOP**

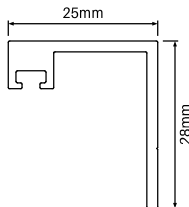

TECH SPECS

- PP 106 / AP 123
- Alloy 6063-T5 / 4200mm long
- Must be used on gates fitted with Lockwood 001 lockbox
- Bulb rubber sold separately (Code: XP-GATESTOP-RUB)
- $l_{xx} = 7.61 \times 10E3 \text{ mmE4}$
- $l_{yy} = 10.95 \times 10E3 \text{ mmE4}$

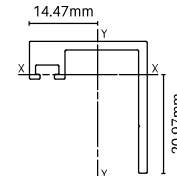

Finishes



GATE EXTRUSIONS



Heavy duty U channel

5000MM LONG

Order Code: **QS-5000-HORIZ**

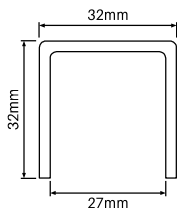

TECH SPECS

- PP 184 / AP 184
- Alloy 6060-T5
- 5000mm long
- 2.5mm wall thickness
- Required for vertical slat pedestrian gates only. Use on both internal vertical sides to reduce light gaps at gate edges
- $lx = 23.97 \times 10E3 \text{ mmE4}$
- $ly = 38.92 \times 10E3 \text{ mmE4}$

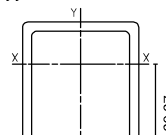

Finishes



9mm gate lockbox kit

SUITABLE FOR LEVER/KNOB LOCK SET

Order Code: **XP-GKIT-LSET09**

- Gate side frame kit is specifically machined to suit horizontal pedestrian gate with lockbox and KNOB/LEVER set
- Patented non-weld assembly system: Use pre-powder coated aluminium lockbox (Code: XP-LBOX-LSET)
- Suits 65x16mm slats with 9mm spacing (Sold separately)
- Lockbox and lever/knob handle sold separately

KIT INCLUSIONS

- 2 x 2094mm long Gate Side Frame slotted with 9mm space (1pc has extra machining for lock set)
- 2 x 2094mm long Gate Inserts
- 1 x 2200mm long Right hand machined Gate Stop
- 1 x 2200mm long Left hand machined Gate Stop
- 1 x 2200mm long non-machined Gate Stop (for hinge side)
- 2 x 2250mm long Gate Stop Rubber
- 2 x Gate Frame Cap - Black nylon
- 1 x 10 pack Wafer head 10-16 x 16mm screws (for affixing gate stop)

Finishes

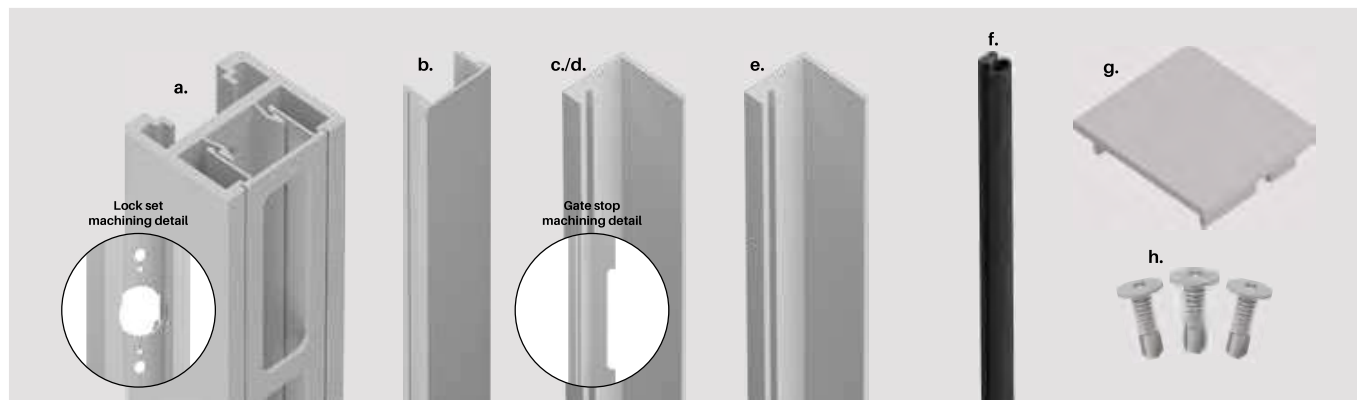

GATE EXTRUSION & ACCESSORIES

20mm gate lockbox kit

SUITABLE FOR LEVER/KNOB LOCK SET

Order Code: **XP-GKIT-LSET20**

- Gate side frame kit is specifically machined to suit horizontal pedestrian gate with lockbox and KNOB/LEVER set
- Patented non-weld assembly system: Use pre-powder coated aluminium lockbox (Code: XP-LBOX-LSET)
- Suits 65x16mm slats with 20mm spacing (Sold separately)
- Lockbox and lever/knob handle sold separately

Finishes



BLACK
(B)



MONUMENT
(MN)



WOODLAND
GREY
(G)



SILVER
(S)



SURFMIST
(SM)



WHITE
(W)



BASALT
(BS)



DUNE
(D)



MILL
(M)

KIT INCLUSIONS

- 2 x 2094mm long Gate Side Frame slotted with 20mm space (1pc has extra machining for lock set)
- 2 x 2094mm long Gate Inserts
- 1 x 2200mm long Right hand machined Gate Stop
- 1 x 2200mm long Left hand machined Gate Stop
- 1 x 2200mm long non-machined Gate Stop (for hinge side)
- 2 x 2250mm long Gate Stop Rubber
- 2 x Gate Frame Cap – Black nylon
- 1 x 10 pack Wafer head 10-16 x 16mm screws (for affixing gate stop)

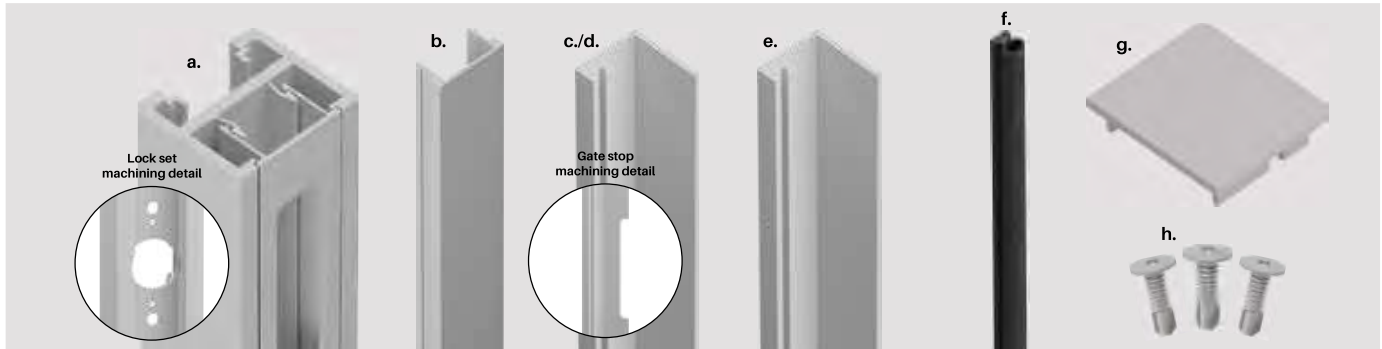

Deadlatch lockbox

ALUMINIUM

Black / Monument / Woodland Grey / Silver / Surfmist / White Basalt / Dune / Mill finish

Order Code: **XP-LBOX-DL**

- Patented non-weld lockbox
- Suits horizontal slat gates with 65x16.5mm slats
- Must use with gate side frame (XP-4200-GSF09/20)
- Screw fix assembly of pre-powder coated lockbox and extrusion
- Suits Lockwood 001 deadlatch (XP-DL001)



Lever/knob lockbox

ALUMINIUM

Black / Monument / Woodland Grey / Silver / Surfmist / White Basalt / Dune / Mill finish

Order Code: **XP-LBOX-LSET**

- Patented non-weld lockbox
- Suits horizontal slat gates with 65x16.5mm slats
- Must use with gate kits (XP-GKIT-LSET09/20)
- Screw fix assembly of pre-powder coated lockbox and extrusion
- Suits knob or lever sets (Stanley or Lockwood models)



Lockwood round knob set

HIGH PURITY ZINC ALLOY

Order Code: **XP-HDL-LW534**

- Lockwood model 534
- Knob set keyed both sides
- Lock / unlock both sides
- Suits left or right gate opening
- Satin Chrome brushed finish
- C4 5 pin on outside
- C4 6 pin restricted compatible on inside



Lockwood 001 deadlatch

12Gx65MM HEX
FLANGE HEAD

Order Code: **XP-DL001**

- Lockwood 001 deadlatch to suit metal frames
- Market leading performance & reliability
- Only suits inwards swinging gate
- Cut-resistant stainless steel bolt



Stanley round knob set

STAINLESS STEEL

Order Code: **XP-HDL-KNOB**

- Knob set keyed both sides
- Lock / unlock both sides
- Suits left or right gate opening
- Stainless steel knob and rose
- C4 6 pin restricted compatible (Inside & outside)



Stanley lever set

STAINLESS STEEL

Order Code: **XP-HDL-LEVER**

- Lever set keyed both sides
- Lock / unlock both sides
- Suits left or right gate opening
- Stainless steel knob and rose
- C4 6 pin restricted compatible (Inside & outside)

GATE ACCESSORIES



Hinge panel brace screws

12Gx40MM – 12 PACK

Black / Monument / Woodland Grey / Silver / Surfmist / White Basalt / Dune / Mill finish

Order Code: XPL-SCHEX-12PK

- Screws fix through post and slat both sides of panel that gate hinges from
- Fix off both sides at top slat and mid slat positions
- Pilot hole required before screw fixing (ensure drill does not penetrate other side of post)
- Must be used to provide rigidity of hinging panel adjacent to gate

Applicable if using XPress PLUS post system next to gate



Finishes



Gate frame cap

NYLON

Black / Monument / Woodland Grey / Silver / Surfmist / White

Order Code: XP-GFC

- UV stabilised nylon – 3mm thick cap
- Available in 5 colours
- Suits gate side frame
- Press-in flat cap

Finishes



Self drilling wafer screws

10Gx16MM – BAG OF 100

Black / Monument / Woodland Grey / Silver / Surfmist / White Basalt / Dune / Mill finish

Order Code: XP-SCREWS

- 10G x 16mm self drilling wafer head zinc plated
- Powder coated heads for neat finish
- Use to screw fix slats to Quickscreen side frame or to affix centre support rail to slats



Countersunk blind rivet

4.0x8.4

Order Code: XP-GATESTOP-RIV-10PK

- Countersunk aluminium rivet – 10 pack
- Use for affixing gate stop to post when using a lockbox with Lockwood 001 deadlatch – due to 3mm gap requirement between gate side frame and post rivets are required (as screw heads may interfere)



PACK OF 10 Gate frame screws

12Gx65MM HEX FLANGE HEAD

Order Code: XP-SCREWSGF-10PK

- Use to secure gate slats to gate side frame through pre-machined holes in gate side frames
- Hex flange head for easy assembly

Electric Striker

Order Code: XP-HDL-ES

- Optional electric striker kit
- SS304 striker – Left or right handing
- Power required to lock/unlock
- 12 volt (DC current)
- LATCHING POST – face mount face plate with built in side keeper
- Requirement to notch latching post to recess electric striker mechanism
- Allow 9mm latching gap
- Compatible with locks:
 - XP-HDL-LW534
 - XP-HDL-KNOB
 - XP-HDL-LEVER

* Routing template included with kit



Gate stop rubber

4300MM LONG

Order Code: XP-GATESTOP-RUB

- Used as bumper for gate stop (mates with XP-4200-GSTOP)
- Rubber feeds into cavity in gate stop extrusion
- Cut to required length

Nylon packer

USE WITH D&D LOKK LATCH DELUXE

Order Code: XP-PACKER

- UV stabilised nylon
- Must be used when installing a D&D Lokk Latch Deluxe
- Packer aligns Lokk Latch Deluxe with gate side frame
- Affixes to inner face of gate side frame positioned under Lokk Latch striker



GATE ASSEMBLY: SIMPLE OVERVIEW

GATE OPTIONS 1, 3 & 4

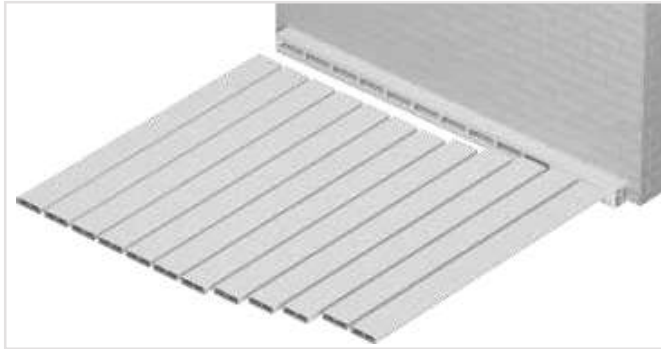

1 On a flat protected surface, lay 1x gate side frame with slotted spacer infill and rest against a padded stop and tap slats and gate blades into place



2 Elevate slats and gate side frame on two padded bearers. Engage second gate side frame to slats and tap frame until all slats are fully engaged
TIP: Start at one end and work slats in from one end to the other



3 Screw off gate blades at required positions. Ensure gate is square by measuring diagonals



4 Slide 2x outer infills down into position to hide screw heads

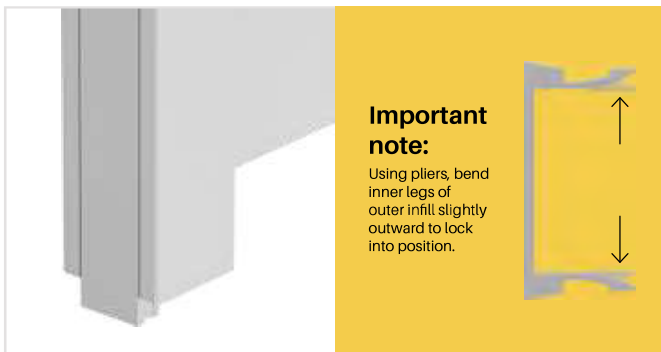

Important note:

Using pliers, bend inner legs of outer infill slightly outwards to lock into position.

5 Slide 2x outer infills past end of gate side frame (approx. 10mm), then using pliers, bend inner legs of outer infill slightly outwards. Tap outer infill back to level with gate side frame

TIP: This step stops the outer infill from sliding down prior to hardware installation



6 Insert top caps into side frames

To determine the actual slat width for your gate, make a deduction of 36mm to the overall gate width (outer edge to outer edge of gate side frame)

FORMULA FOR SLAT WIDTH:
OVERALL GATE WIDTH – 36MM

You need to allow for hinge and latch gaps
Check hinge and latch hardware specifications for gaps required and take this information into account when determining overall gate width

Contact us for further installation instructions when using lockboxes etc.

GATE ASSEMBLY

GATES WIDER THAN 1500MM

- 1 When the gate is wider than 1500mm, 2x heavy duty top/bottom rails are used in place of the top and bottom gate blades (Additional gate blades are still required as per page 63).

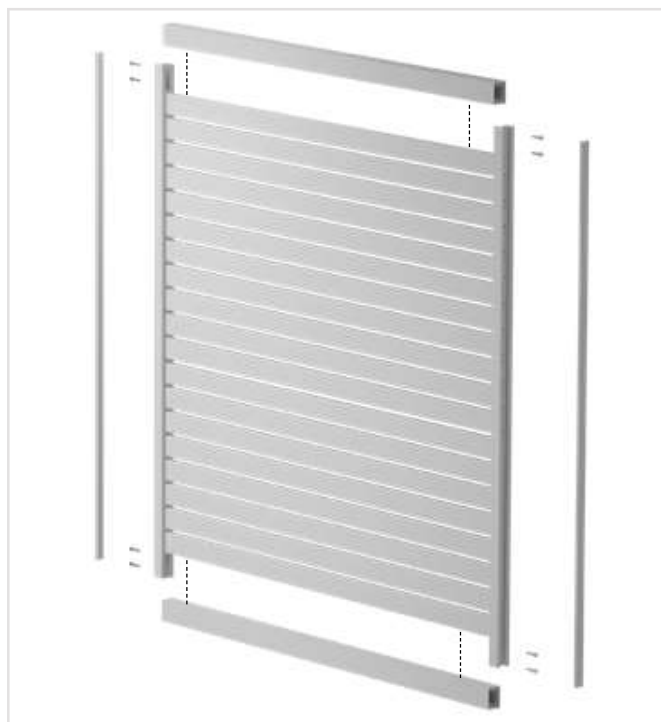

- 2 Once top/bottom rails and all slats are installed, ensure gate is square. The slimline brace must be measured and cut with an aluminium drop saw to run diagonally across the back face of the gate. Secure each slat using XP-SCREWS.

IMPORTANT:

Ensure the slimline brace is installed running from the 'bottom' hinge side corner to the top 'latch' side corner



SUGGESTED HINGE FIXING METHOD USING 65MM M8 BOLTS, SPRING WASHERS & NUTS FOR GATES 1500MM AND UNDER

* Hinge fixings not supplied

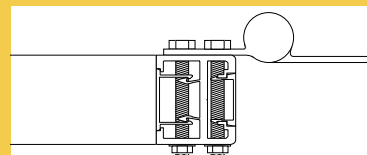

Our range of gate hinges

D&D hinges available as single items or buy in carton lots for large bulk buy discounts on selected lines



D[®] TRUClose[®]

TruClose[®] hinge pair
NO ALIGNMENT LEGS
Order Code: TC-H-AT-B
D&D Code: TCA1S3BT



D[®] TRUClose[®]

TruClose[®] hinge pair
2 ALIGNMENT LEGS
Order Code: TC-H-AT-2L-B
D&D Code: TCA1L23BT



D[®] TRUClose[®] HEAVY DUTY

TruClose[®] hinge pair
Heavy duty
1 ALIGNMENT LEG
Order Code: TC-H-AT-HD-B
D&D Code: TCHD1AL1S3BT



D[®] TRUClose[®] HEAVY DUTY

TruClose[®] hinge pair
Heavy duty
2 ALIGNMENT LEGS
Order Code: TC-H-AT-HD-2L-B
D&D Code: TCHD1AL2S3BT



D[®] KWIKFit[®]

Kwik Fit[®] hinge pair
FIXED TENSION
Order Code: KF-H-FT
D&D Code: KF35



D[®] KWIKFit[®]

Kwik Fit[®] hinge pair
NO TENSION
Order Code: KF-H-NT
D&D Code: KF3P



D[®] KWIKFit[®] ALUMINIUM

Kwik Fit[®] Aluminium
hinge pair
ADJUSTABLE TENSION
Order Code: KF-AH-AT
D&D Code: KF3ABL



SureClose[®] Readyfit
hydraulic hinge closer
2 ALIGNMENT LEGS
Order Code: SURECLOSE -HH
D&D Code: 74108313



SureClose[®] Readyfit
hinge non self closing
closer
2 ALIGNMENT LEGS
Order Code: SURECLOSE -NSC
D&D Code: 74001313

GATE HINGES

19mm
gap spacing

No
alignment legs

(variable spacing achievable)



Certi cap – Series 3

Order Code: TC-CAPS3

D&D code: TCACAP53

- Prevents toe hold on hinge
- Durable polymer material



TruClose® hinge pair

NO ALIGNMENT LEGS

Order Code: TC-H-AT-B (Pair)
BB-TC-H-AT-B (*Bulk buy)

D&D code: TCA1S3BT

- D&D patented tension adjustment
- Strong, moulded polymer and stainless steel
- Adjust tension from both ends of the hinge
- No visible fixings
- Decorative trim covers available in black finish
- Super strong engineering polymers and stainless steel components
- Won't rust, bind, sag or stain
- Limited lifetime warranty
- Pool fencing compliant – Rated for gates up to 30kg

No alignment legs on hinge allows for flexibility when positioning gate onto post

*BULK BUY CARTON QTY: 20 PAIRS

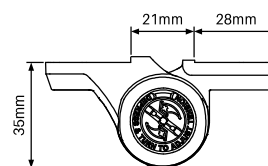
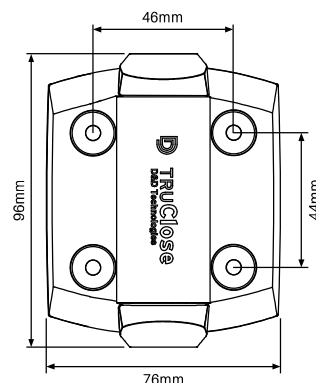

Reinforcing ribs
Moulded ribs provide super strength

Concealed fasteners
Trim covers hide the fasteners to improve the appearance of the gate



Patented adjuster
Easy tension adjustment

Internal stainless steel spring
Won't rust or corrode

Moulded hinge body
Engineering polymers with glass fibre reinforcement are UV stabilised

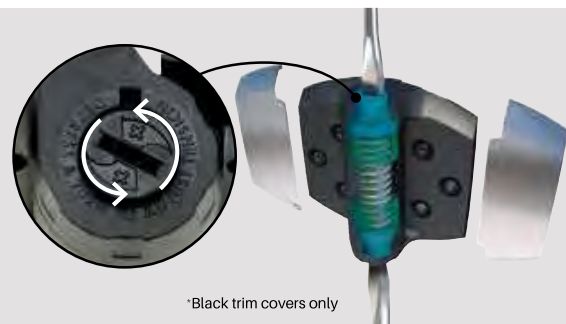

*Black trim covers only

21mm
gap spacing

2
alignment legs



Certi cap – Series 3

Order Code: TC-CAPS3

D&D code: TCACAP53

- Prevents toe hold on hinge
- Durable polymer material



TruClose® hinge pair

2 ALIGNMENT LEGS

Order Code: TC-H-AT-2L-B (Pair)
BB-TC-H-AT-2L-B (*Bulk buy)

D&D code: TCA1L2S3BT

- D&D patented tension adjustment
- Strong, moulded polymer and stainless steel
- Adjust tension from both ends of the hinge
- No visible fixings
- Decorative trim covers available in black finish
- Super strong engineering polymers and stainless steel components
- Won't rust, bind, sag or stain
- Limited lifetime warranty
- Pool fencing compliant – Rated for gates up to 30kg

Two alignment legs on hinge allows for quick, easy and accurate positioning of gate onto post

*BULK BUY CARTON QTY: 20 PAIRS

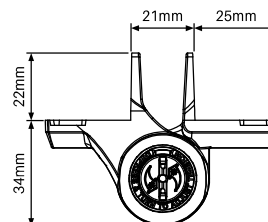
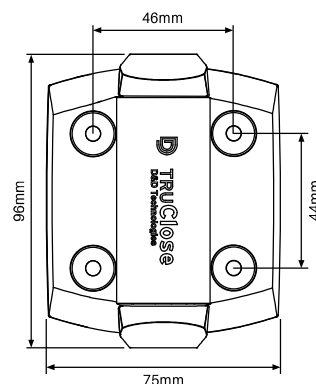

GATE HINGES

19mm
gap spacing

1
alignment leg



TRUClose® HEAVY DUTY

TruClose® hinge pair Heavy duty

1 ALIGNMENT LEG

Order Code: TC-H-AT-HD-B (Pair)
BB-TC-H-AT-HD-B (* Bulk buy)

D&D code: TCHD1AL1S3BT

- D&D patented tension adjustment
- Strong, moulded polymer and stainless steel
- Adjust tension from both ends of the hinge
- No visible fixings
- Decorative trim covers available in black finish
- Super strong engineering polymers and stainless steel components
- Won't rust, bind, sag or stain
- Limited lifetime warranty
- Pool fencing compliant - Rated for gates up to 70kg

One alignment leg on hinge allows for quick and sturdy fixing on one side with flexible positioning on the other side

*BULK BUY CARTON QTY: 20 PAIRS

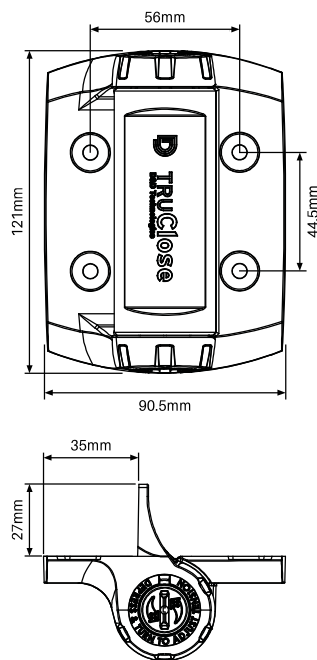

21 mm
gap spacing

2
alignment legs



TRUClose® HEAVY DUTY

TruClose® hinge pair Heavy duty

2 ALIGNMENT LEGS

Order Code: TC-H-AT-HD-2L-B (Pair)
BB-TC-H-AT-HD-2L-B (* Bulk buy)

D&D code: TCHD1AL2S3BT

- D&D patented tension adjustment
- Strong, moulded polymer and stainless steel
- Adjust tension from both ends of the hinge
- No visible fixings
- Decorative trim covers available in black finish
- Super strong engineering polymers and stainless steel components
- Stylish and contemporary design
- Won't rust, bind, sag or stain!
- Limited lifetime warranty
- Pool fencing compliant - Rated for gates up to 70kg

Two alignment legs on hinge allows for quick, easy and accurate positioning of gate onto post

*BULK BUY CARTON QTY: 20 PAIRS

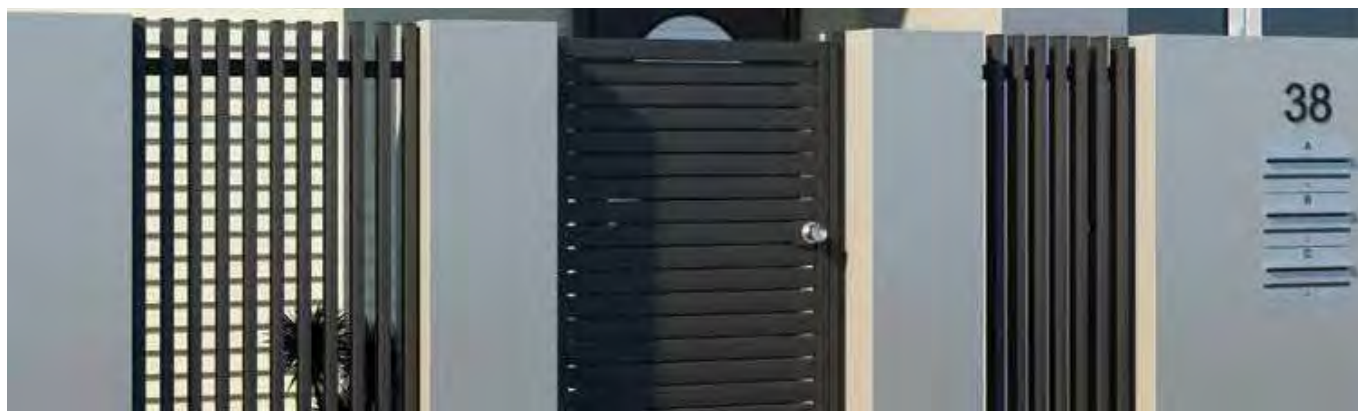
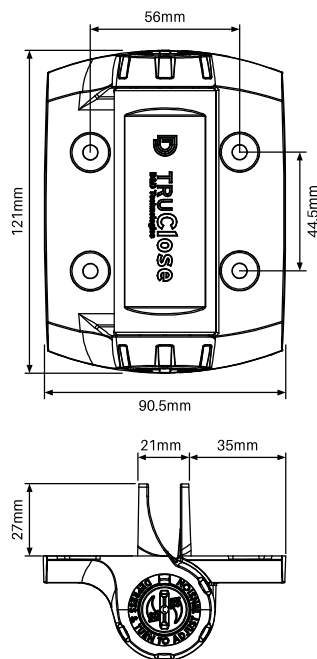

GATE HINGES

20mm
gap spacing

Fixed tension



Kwik Fit® hinge pair

FIXED TENSION

Order Code: KF-H-FT (Pair)
BB-KF-H-FT (*Bulk buy)

D&D code: KF35

- Self closing fixed tension hinges
- Rated to 20kg self close (D&D)
- Alignment legs for ease of fitting
- Strong polymer and stainless steel
- Torsion spring construction
- Pool fencing compliant

*BULK BUY CARTON QTY: 50 PAIRS

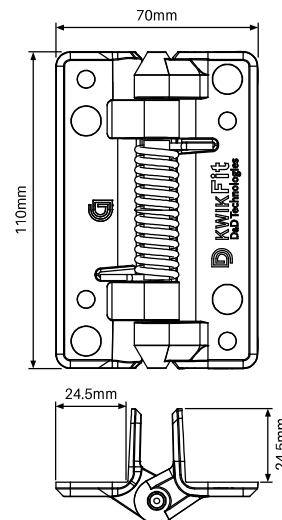

20mm
gap spacing

No tension



Kwik Fit® hinge pair

NO TENSION

Order Code: KF-H-NT (Pair)
BB-KF-H-NT (*Bulk buy)

D&D code: KF3P

- Standard pivot hinges (No self close)
- Rated to 25kg gates (D&D)
- Alignment legs for ease of fitting
- Strong polymer construction
- Ideal for boundary gates

*BULK BUY CARTON QTY: 50 PAIRS

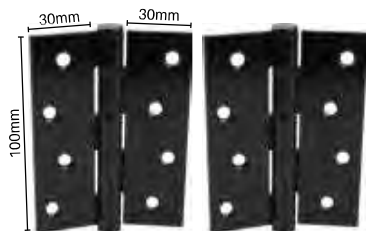
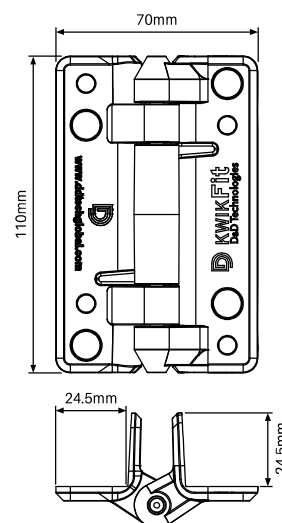

Butt hinge pair

100MM H x 75MM W

Order Code: SS-BH10075-B

- Cost effective where self closing hinge is not required
- Zinc plated steel
- Powder coated black
- Multiple fixing points – Ø6mm holes
- Not self closing



Butt Hinge Pair

PAIR OF 2
(includes 17 x matching colour tek screws)

17 x tek screws

Order Code: CB-HINGE-B-2PK

- Made from galvanised steel & powder coated
- 6.5mm diameter fixing holes
- 2.5mm thick hinge leaf

Finishes

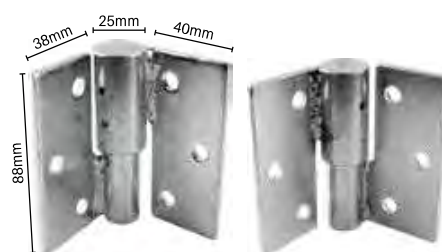

Zeus hinges

Order Code: ZF-BBH-L/R (Left/Right)

- Bolt on ball bearing hinge pair
- Left and right hinges available
- Galvanised steel construction
- Sturdy, long lasting hinges
- Suits heavy/wide hinge gates
- Not self closing

GATE HINGES

19mm
gap spacing

Adjustable
tension

D **KWIKFit** **ALUMINIUM**

Kwik Fit® Aluminium hinge pair

ADJUSTABLE TENSION

Order Code: **KF-AH-AT (Pair)**
BB-KF-AH-AT (*Bulk buy)

- D&D code: KF3ABL
- Powder coated black aluminium hinges
 - D&D patented tension adjustment – 6 tension settings, adjustable from both ends
 - Self closing hinge – closes gates up to 20kg
 - Internal stainless steel spring
 - Wall and post mounting hinges
 - Tested to over 300,000 cycles
 - Pool fencing compliant

*BULK BUY CARTON QTY: 16 PAIRS

POST TO GATE
INSTALLATION



OR

WALL TO GATE
INSTALLATION



Wall to gate installation

Fit to posts or walls
Adjustable fixing plate

POST TO GATE INSTALLATION

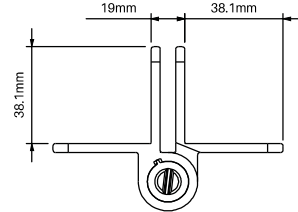

WALL TO GATE INSTALLATION

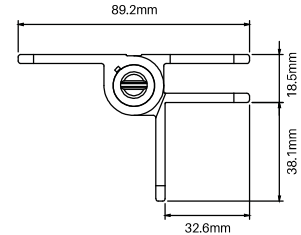

12-35mm
gap spacing



FIXING SCREWS SUPPLIED
MIN POST SIZE: 50MM

Sureclose – Readyfit hinge

HYDRAULIC HINGE CLOSER 2 ALIGNMENT LEGS

Order Code: **SURECLOSE-HH**
D&D Order Code: **74108313**

- Ideal for commercial/industrial applications
- Easy install – screw on externally mounted
- Self close gates up to 120kg
- Heavy duty, 50 micron black anodised aluminium
- Sold as SINGLE hinge
- SELF CLOSING FROM 83 degrees
- HOLES OPEN AT 90 deg to 180 deg
- MAX GATE OPENING 178 deg

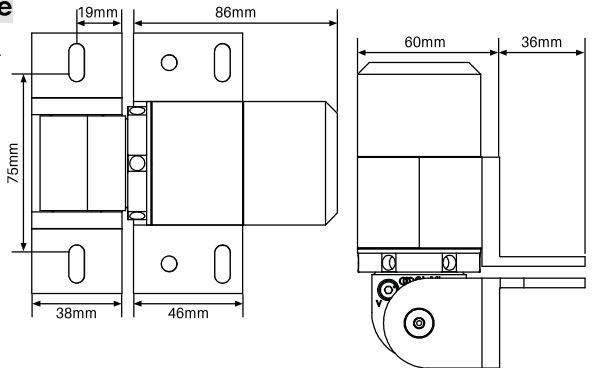

TRADE TIP: Commonly a hydraulic closer hinge is installed on the bottom of the gate (SURECLOSE-HH) with the non self closing hinge at top of gate (SURECLOSE-NSC). For very heavy gates, 2 x closer hinges may be considered.

12-35mm
gap spacing



FIXING SCREWS SUPPLIED
MIN POST SIZE: 50MM

Sureclose – Readyfit hinge

NON SELF CLOSING CLOSER 2 ALIGNMENT LEGS

Order Code: **SURECLOSE-NSC**
D&D Order Code: **74001313**

- Ideal for commercial/industrial applications
- Easy install – screw on externally mounted
- NON SELF CLOSING hinge
- Heavy duty, 50 micron black anodised aluminium
- Sold as SINGLE hinge
- LOAD BEARING non self closing hinge
- MAX GATE OPENING 178 deg

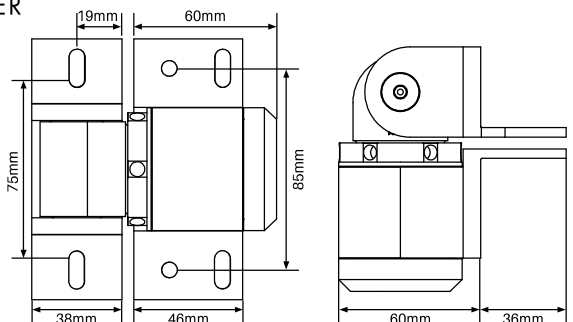

Our range of gate latches

D&D latches available as single items or buy in carton lots for large bulk buy discounts



D LOKK**Latch** DELUXE

Lokk Latch® deluxe

KEYED ALIKE

Order Code: LL-DL-KA

D&D Code: LLDABS2LA



D LOKK**Latch** DELUXE

Lokk Latch® deluxe

KEYED TO DIFFER

Order Code: LL-DL

D&D Code: LLDABS2-L



D LOKK**Latch**

Lokk Latch®

KEYED TO DIFFER

Order Code: LLAA

D&D Code: LLAA



D LOKK**Latch**

Lokk Latch® external access kit

KEYED TO DIFFER

Order Code: LLB

D&D Code: LLB



D MAGNA**Latch**

Top pull lockable latch

Order Code: ML-TL

D&D Code: ML3TPLA



D D&D Technologies
Hi-Performance Hardware

Face mount lockable latch

Order Code: MR-FMLS1

D&D Code: MLSPS2L



D D&D Technologies
Hi-Performance Hardware

T latch

Order Code: T-L

D&D Code: TL01



D latch

Order Code: SS-DL-B

GATE LATCHES

15-40mm
gap spacing

KEYED ALIKE



LOKKLatch DELUXE

Lokk Latch® deluxe

Order Code: LL-DL-KA (Single)
BB-LL-DL-KA (*Bulk buy)

D&D code: LLDABS2LA

- Lockable from both sides of gate
- Locks are keyed alike
- Rekeyable, 6-pin security lock
- Fits up to 150mm deep posts
- Black polymer

*BULK BUY CARTON QTY: 20PCS

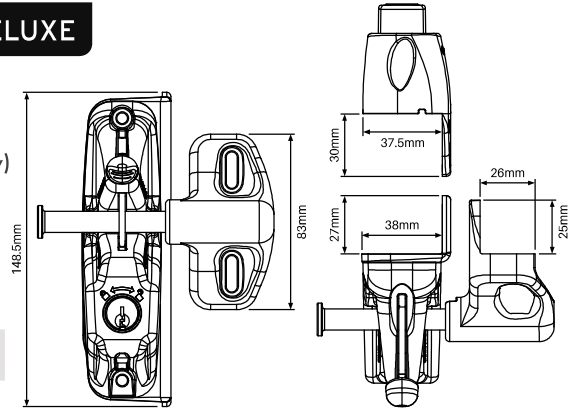

15-40mm
gap spacing

KEYED TO DIFFER



LOKKLatch DELUXE

Lokk Latch® deluxe

Order Code: LL-DL (Single)
BB-LL-DL (*Bulk buy)

D&D code: LLDABS2-L

- Lockable from both sides of gate
- Locks are keyed to differ
- Rekeyable, 6-pin security lock
- Fits up to 150mm deep posts
- Black polymer

*BULK BUY CARTON QTY: 20PCS

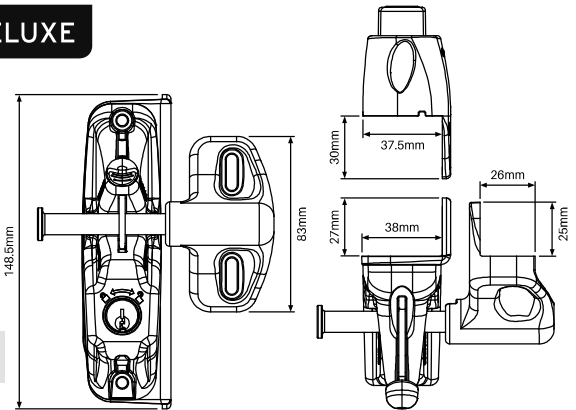

15-40mm
gap spacing

KEYED TO DIFFER



LOKKLatch

Lokk Latch®

Order Code: LLAA (Single)
BB-LLAA (*Bulk buy)

D&D code: LLAA

- Ideal latch for home and garden gates
- Key lockable - no need for padlocks or chains
- Fit with or without External Access Kit (LLB)
- Quick and easy to install on all gate materials
- Strong polymer design will not rust or stain
- Minimum post size for fitting - 25mm

*BULK BUY CARTON QTY: 20PCS

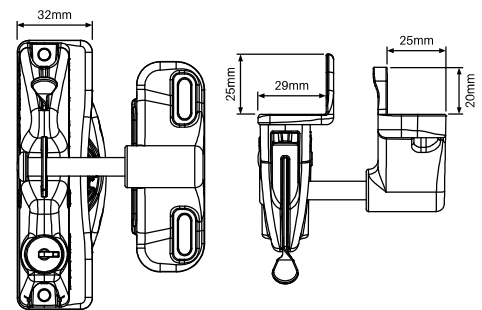

LOKKLatch

Lokk Latch® external access kit

Order Code: LLB (Single)
BB-LLB (*Bulk buy)

D&D code: LLB

- Optional extra external access kit
- Matches with LLAA
- Allows opening of LLAA from other side of gate
- NOTE: locking external access button does not lock the main latch

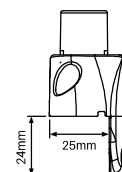

*BULK BUY CARTON QTY: 10PCS

GATE LATCHES

13-38mm
gap spacing



Top pull lockable latch

Order Code: **ML-TL (Single)**
BB-ML-TL (*Bulk buy)

D&D code: ML3TPLA

- Magnetically triggered lockable latch
- Improved stylish "Series 3" design
- Adjusts horizontally and vertically
- Includes adjustable striker plate
- D&D Limited lifetime warranty
- Quick and easy installation
- Tested to over 400,000 cycles

*BULK BUY CARTON QTY: 20PCS

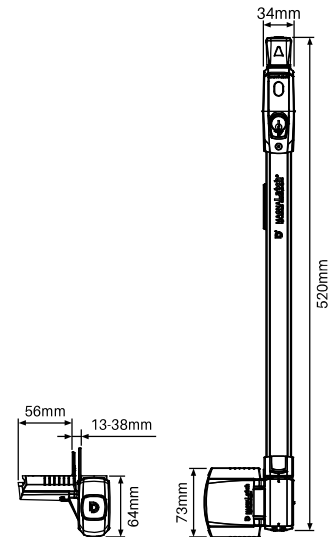

8-10mm
gap spacing



Face mount lockable latch

Order Code: **MR-FMLS (Single)**
BB-MR-FMLS (*Bulk buy)

D&D code: MLSP52L

- Suits retrofitting to previously fitted standard side pull latch installations
- Key lockable
- Adjusts horizontally and vertically
- Limited lifetime warranty
- Black polymer

*BULK BUY CARTON QTY: 10PCS

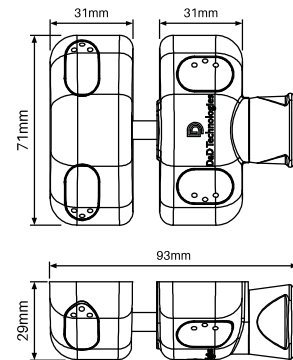

10-45mm
gap spacing



*Padlock not included



T latch

Order Code: **T-L (Single)**
BB-T-L (*Bulk buy)

D&D code: TL01

- Padlockable toggle latch
- Lockable from one side only

*BULK BUY CARTON QTY: 20PCS

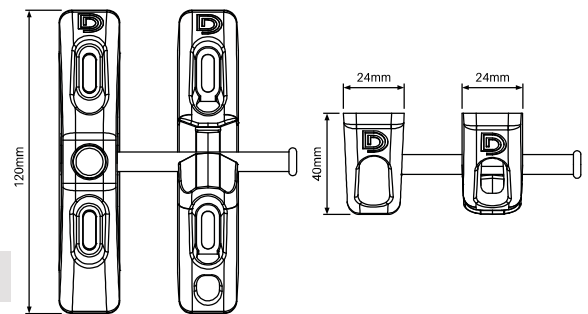

10-35mm
gap spacing



D latch

Order Code: **SS-DL-B**

- Easy to install D latch and striker
- Includes 4x tek screws
- Cost effective latching solution

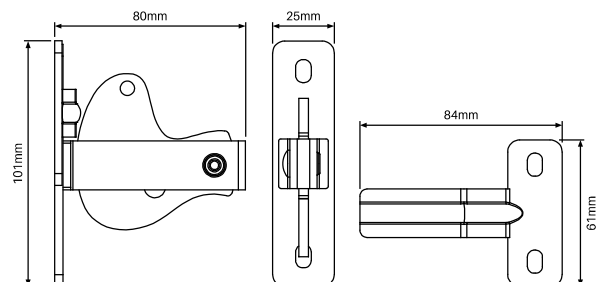

GATE LATCH & HINGE KITS



Magna Latch® with Kwik Fit® hinge pair

FIXED TENSION

Order Code: **ML-TL-KF-H-FT (Single)**
BB-ML-TL-KF-H-FT (*Bulk buy)

D&D code: ML3KF5K

- Kit includes D&D top pull Magna latch and 2x KWIK fit hinges (KF3S model)
- Self closing fixed tension hinges (20mm gap for hinges)
- Pool fencing compliant - Rated for gates up to 20kg
- Magnetically triggered lockable latch

*BULK BUY CARTON QTY: 20PCS

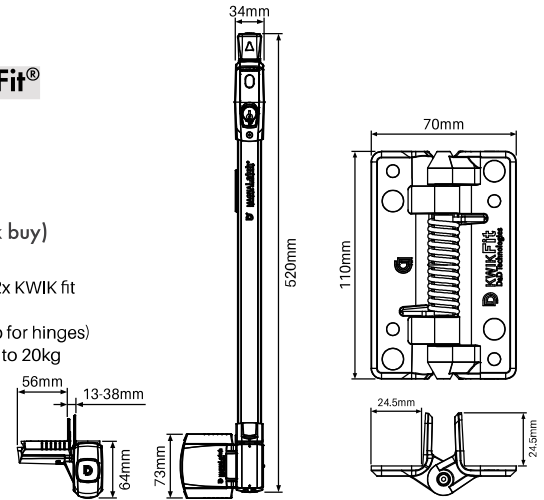

Magna Latch® with Tru Close® hinge pair

ADJUSTABLE TENSION

Order Code: **ML-TL-TC-H-AT (Single)**
BB-ML-TL-TC-H-AT (Bulk buy)

D&D code: MTSTDK53LA

- Kit includes D&D top pull Magna latch and 2x TRU close hinges
- Patented tension adjustable hinges (TC-H-A-B version hinges - no alignment legs on hinges provides for flexible installation)
- Pool fencing compliant - Rated to 25kg self close
- Magnetically triggered lockable latch

*BULK BUY CARTON QTY: 20PCS

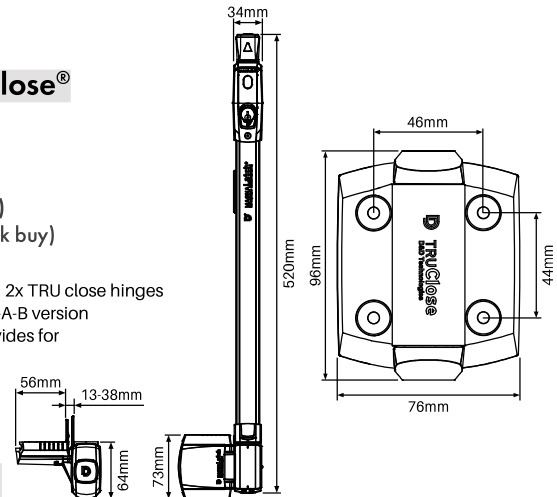

Self drilling tek screws

12Gx20mm – BAG OF 100

Black, Woodland Grey, Monument, Primrose, Paperbark, Silver, Surfmist & White

Order Code: SS-TS-100

- Self drilling tek screw featuring integrated thread and drill/cutting tip
- 12G x 20mm tek screw with hex head
- Packed in convenient bags of 100 screws



Soudal CA1400 Chemical anchor

280mL

Order Code: SOUD-CA1400

- High performance, two-component chemical anchoring resin for the pressure-free securing of anchoring rods, studs, threaded collars etc
- Fast cure
- Vinyl ester styrene free
- Can be used in damp concrete
- Apply with standard caulking gun

FENCING ACCESSORIES

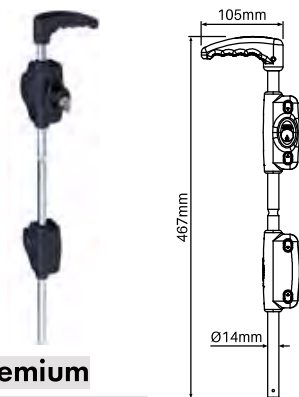

D&D Premium lockable drop bolt

Black finish

Order Code: LB-PL (Single)
BB-LB-PL (*Bulk buy)

*BULK
BUY QTY:
10PCS

D&D code: LL118BX-LA

- 316 marine-grade stainless steel drop-bolt
- Tough polymer-housing mounting system
- 6-pin lock (rekeyable to match doors & gate locks)



D&D Padlockable drop bolt

Black finish

Order Code: QB124 (Single)
BB-QB124 (*Bulk buy)

*BULK
BUY QTY:
10PCS

D&D code: QB124

- Powder coated black, stainless steel drop-bolt
- Padlockable (*Padlock not included)
- Tough, moulded polymer mounting system



300mm drop bolt

Black or zinc plated finish

Order Code: SS-0300DB-B/ZP

- Ideal for driveway gates
- Cost effective drop bolt
- Easy to install



D&D Gate handle

Black polymer finish

Order Code: LL-GH (Single)
BB-LL-GH (*Bulk buy)

*BULK
BUY QTY:
20PCS

D&D code: LL3GH

- Side-fixing legs for quick alignment
- Fits left-hand or right-hand opening gates
- Won't rust or stain: strong polymer construction

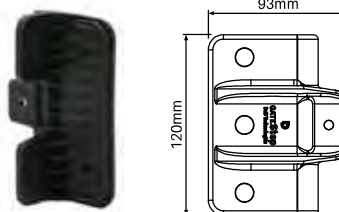

D&D Gate stop

Black polymer finish

Order Code: SS-GS (Single)
BB-SS-GS (*Bulk buy)

*BULK
BUY QTY:
10PCS

D&D code: TCGS3

- Ideal gate alignment device
- Prevents damage to latches & hinges
- Greatly reduces gate-slam noise
- Tough, durable polymer + rubber bumper



Now available in white!

Post plugs – 4 pack

Black or White finish

Order Code: SS-POSTPLUG-4PK
SS-POSTPLUG-4PK-W

- Ø32mm outer top suits 25mm hole
- Suits post wall thickness 1.5mm - 3.2mm
- Cap holes in posts when fixing posts to structures



Bostik V60 Clear glazing silicone

300g

Order Code: FB-V60

- Architectural grade high performance glazing silicone
- Neutral cure sealant specially formulated - skins quickly and provides long term performance
- Seals water tight - UV and weather resistant
- Compatible substrates glass, steel, timber, concrete, ceramic, fiberglass, aluminium (powder coated surfaces are limited)



Soudal heavy duty cartridge gun

Order Code: SOUD-GUN

- Heavy duty, steel trade quality cartridge gun
- Geared ratio 18:1 for smooth operation and easy application
- Dripless system feature automatically releases pressure to reduce mess/waste
- Suits 300ml silicone cartridges and 280ml chemical anchor



Soudal Epofix 82A

300g

Order Code: SOUD-EPOFIX

- 24ml bottle
- Translucent fast curing 2 part epoxy
- Very strong bonding of many types of materials including metal, wood, glass and plastics

Our range of white



AUSTRALIAN INDUSTRY FIRST



GENUINE D&D WHITE HARDWARE



D[®] **TRUClose**[®]

TruClose[®] hinge pair

2 ALIGNMENT LEGS

Order Code: TC-H-AT-2L-W



D[®] **TRUClose**[®] **HEAVY DUTY**

TruClose[®] hinge pair

Heavy duty

2 ALIGNMENT LEGS

Order Code: TC-H-AT-HD-2L-W



D[®] **KWIKFit**[®] **ALUMINIUM**

Kwik Fit[®] Aluminium
hinge pair

ADJUSTABLE TENSION

Order Code: KF-AH-AT-W



D[®] **LOKKLatch**[®]

Lokk Latch[®]

KEYED TO DIFFER

Order Code: LLA-W



D[®] **LOKKLatch**[®] **DELUXE**

Lokk Latch[®] deluxe

KEYED TO DIFFER

Order Code: LL-DL-W



D[®] **TRUClose**[®] **HEAVY DUTY**

D[®] **LOKKLatch**[®] **DELUXE**

**Lokk latch deluxe &
TruClose heavy duty
hinge pair**

HINGE & LATCH KIT

Order Code: LLDL-TCHD-W

21 mm
gap spacing

2
alignment legs



Two alignment legs on hinge allows for quick, easy and accurate positioning of gate onto post



TruClose® hinge pair

2 ALIGNMENT LEGS

Order Code: TC-H-AT-2L-W (Pair)
BB-TC-H-AT-2L-W (Bulk Buy)

- D&D patented tension adjustment
- Strong, moulded polymer and stainless steel
- Adjust tension from both ends of the hinge
- No visible fixings
- Super strong engineering polymers and stainless steel components
- Won't rust, bind, sag or stain
- Limited lifetime warranty
- White polymer
- Pool fencing compliant - Rated for gates up to 30kg

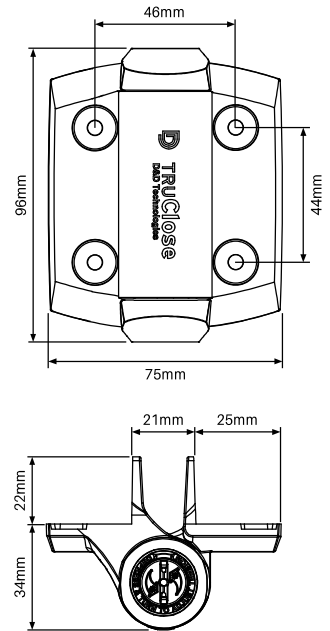

21 mm
gap spacing

2
alignment legs



Two alignment legs on hinge allows for quick, easy and accurate positioning of gate onto post



TruClose® hinge pair

Heavy duty

2 ALIGNMENT LEGS

Order Code: TC-H-AT-HD-2L-W (Pair)
BB-TC-H-AT-HD-2L-W (Bulk Buy)

- D&D patented tension adjustment
- Strong, moulded polymer and stainless steel
- Adjust tension from both ends of the hinge
- No visible fixings
- Super strong engineering polymers and stainless steel components
- Stylish and contemporary design
- Won't rust, bind, sag or stain!
- Limited lifetime warranty
- White polymer
- Pool fencing compliant - Rated for gates up to 70kg

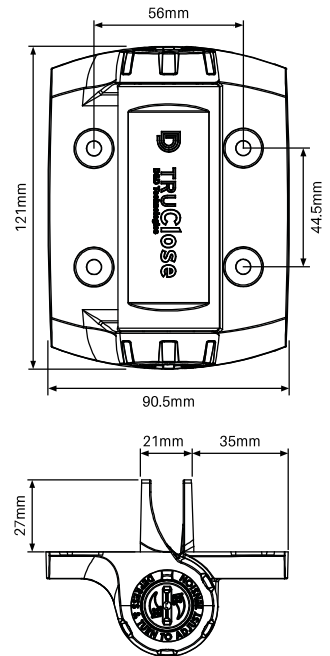

19mm
gap spacing

Adjustable
tension

POST TO GATE
INSTALLATION



Kwik Fit® Aluminium hinge pair

ADJUSTABLE TENSION

Order Code: KF-AH-AT-W (Pair)
BB-KF-AH-AT-W (Bulk Buy)

- Powder coated white aluminium hinges
- D&D patented tension adjustment - 6 tension settings, adjustable from both ends
- Self closing hinge - closes gates up to 20kg
- Internal stainless steel spring
- Wall or post mounting hinges
- Tested to over 300,000 cycles
- Pool fencing compliant

Fit to posts or walls

Adjustable fixing plate

POST TO GATE INSTALLATION

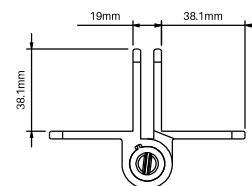

WALL TO GATE INSTALLATION

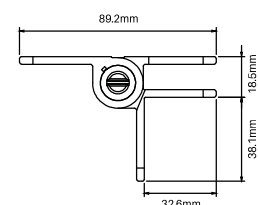

WHITE GATE LATCHES

15-40mm
gap spacing

KEYED TO DIFFER



LOKK Latch®

Lokk Latch®

Order Code: **LLAA-W**
BB-LLAA-W (Bulk Buy)

- Ideal latch for home and garden gates
- Key lockable – no need for padlocks or chains
- Quick and easy to install on all gate materials
- Strong polymer design will not rust or stain
- Minimum post size for fitting – 25mm
- White polymer

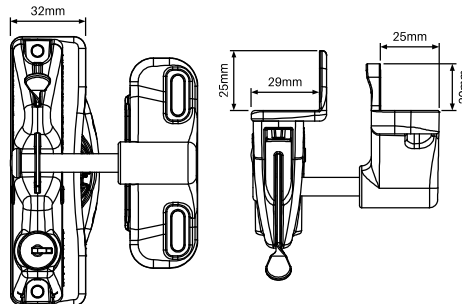

15-40mm
gap spacing

KEYED TO DIFFER



LOKK Latch® DELUXE

Lokk Latch® deluxe

Order Code: **LL-DL-W**
BB-LL-DL-W (Bulk Buy)

- Lockable from both sides of gate
- Locks are keyed to differ
- Rekeyable, 6-pin security lock
- Fits up to 150mm deep posts
- White polymer

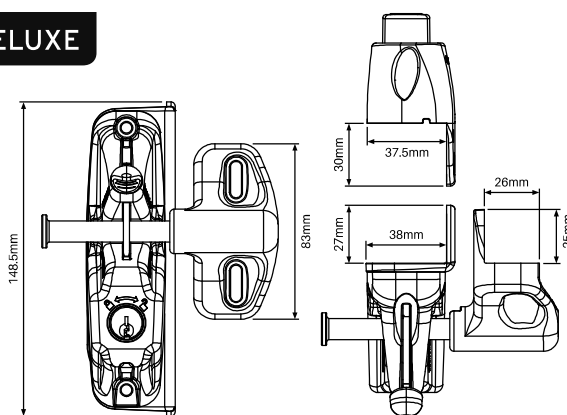

GATE LATCH & HINGE KIT

21 mm
hinge gap spacing

2
alignment legs



TRUclose® HEAVY DUTY

LOKK Latch® DELUXE

Lokk latch deluxe & TruClose hinge pair Heavy duty

HINGE & LATCH KIT

Order Code: **LLDL-TCHD-W**
BB-LLDL-TCHD-W (Bulk Buy)

- Kit includes D&D Lokk Latch Deluxe and 2x TRU close hinges heavy duty
- Pool fencing compliant - Rated to 70kg self close
- Latch is lockable from both sides of gate
- Ideal for aluminium screening & Hamptons gates
- White polymer

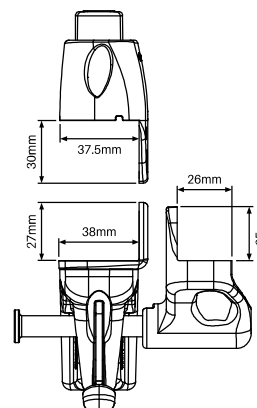
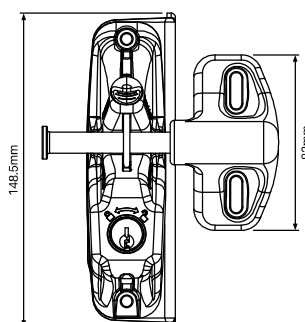
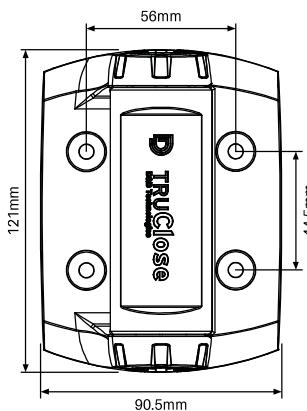

15-40mm
latch gap spacing

+
keyed to differ

GUIDE POST & EXTENSION

65x65mm steel post

2700MM LONG

Order Code: XPSG-2700-ST65

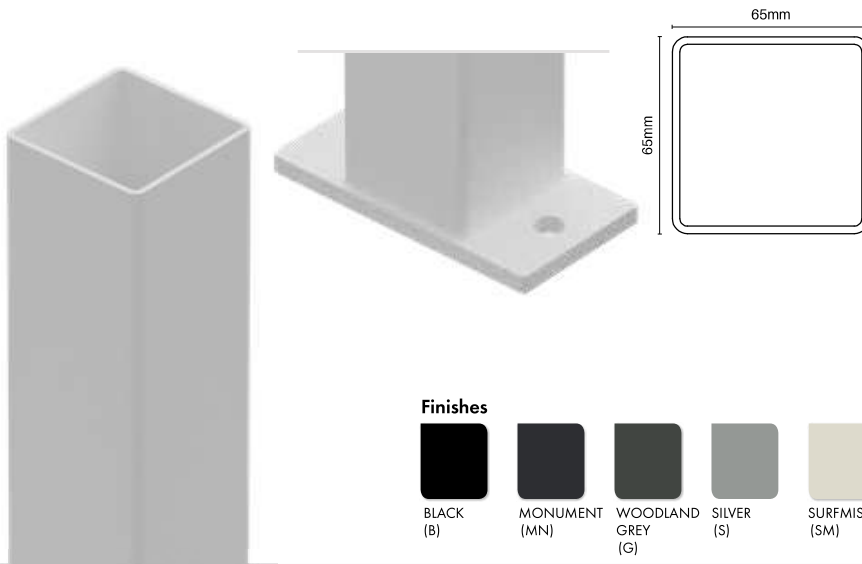

TECH SPECS

- 65x65mm galvanised steel post
- Includes press in black cap
- 2.5mm wall thickness
- Use at gate end to affix guide rollers or slide guide
- May also be used at gate front for affixing U or F catch
- Includes press in black cap
- Includes welded on 8mm thick base plate with 2 x 12.8mm diam fixing holes - use for base plated post fixing or bury into concrete for superior anchoring

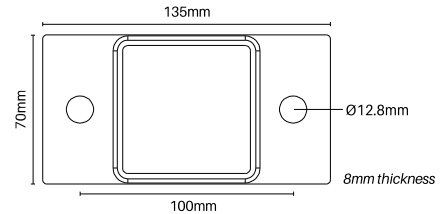

Finishes



Sliding gate extension

400MM LONG

Order Code: XPSG-MXTN-KIT



TECH SPECS

- 400mm long bottom rail extension
- Optional extra - useful where extra length required for motor rack to be affixed to bottom rail.
- Not required for every slide gate install. Recommended only where install situation requires
- Extension piece fixes to gate side frame
- Fixing bolts and plates included in kit

Finishes



Simply bolt onto bottom of gate side frame during assembly process

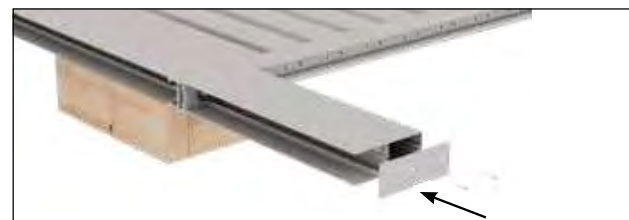
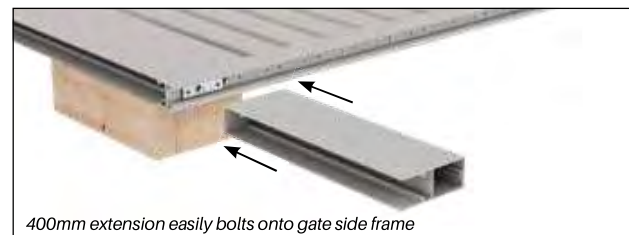

GATE ACCESSORIES

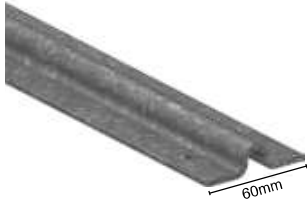

Steel sliding gate track

3000MM LONG OR
6000MM LONG

Order Codes:
XPSG-3000-TRACK-ST (3000mm)
XPSG-6000-TRACK-ST (6000mm)

- Available 3000mm or 6000mm long
- Made from 3mm galvanised steel for durability
- Bolt down sliding gate track with a Ø20mm running surface
- Easy to install with predrilled fixing holes (22 holes for 3000mm track and 42 holes for 6000mm track)

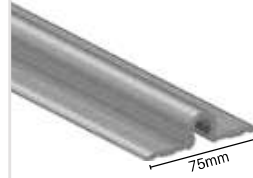

Aluminium sliding gate track

6000MM LONG

Order Code:
XPSG-6000-TRACK-AL (6000mm)

- Available 6000mm long
- Mill finish aluminium - 6063-T5
- Bolt down sliding gate track with a Ø20mm running surface
- No drill holes - drill fixing holes as needed



Sliding gate track pins

Order Code: XPSG-ANCHOR

- Mushroom head galvanised steel track anchor pins
- 6.5mm x 38mm
- Pre-expanded expansion anchor. Once hammered in, unique kinked shaft provides a spring action for vibration proof anchoring. Use 6.5mm masonry bit into concrete

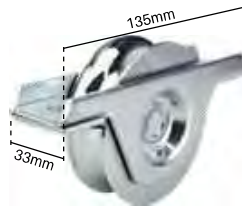

Sliding gate wheel

Order Code: XPSG-WHEEL

- 80mm diameter with 20mm diameter groove
- Zinc plated steel
- Load rating 180kg
- Use with 1 x XPSG-WHEEL-CS clamping set to fix to sliding gate bottom rail
- Made in Italy



Sliding gate wheel clamping set

Order Code: XPSG-WHEEL-CS

- Use to clamp sliding gate wheel to bottom rail
- Aluminium M8 threaded block
- Includes 2 x zinc plated screws
- Sold as a pack of 2 (suits 1 x wheel)



Slide guide

Order Code: XPSG-GUIDE

- Self-adjusting slide guide attaches to sliding gate top rail
- Keeps gate in vertical position and travelling true while opening/closing
- As gate travels along track and shifts up or down, slide guide adjusts automatically. Up to 280mm vertical adjustment.
- Guide channel is anodised black with sturdy nylon block

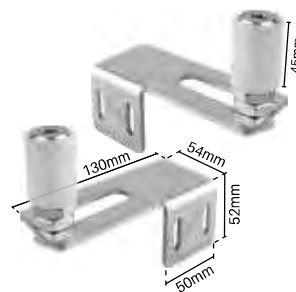

Sliding gate guide rollers

2 PACK

Order Code: XPSG-TOPROLL-2PK

- Alternative to SlideGuide
- Rollers guide top rail while gate opens and closes
- Can only be used if vertical deviation of gate while travelling is 15mm or less
- White nylon rollers - made in Italy
- Kit includes 1 x left and 1 x right zinc plated steel mounting bracket (fixings not included) - 30mm hole centers

2 installation methods —

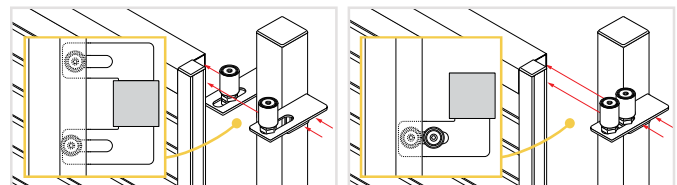

GATE ACCESSORIES

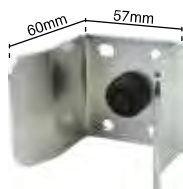

Gate U catch

Order Code: XPSG-CATCH-U

- Suits up to 50mm gate frames
- Gate catch supplied with 5 pre-drilled holes for easy installation and adjustment
- Rubber stop provided for noise reduction
- Steel zinc plated



Gate F catch

Order Code: XPSG-CATCH-F

- Suits up to 50mm gate frames
- Affix bracket to wall/post via "F" leg
- U catch attaches to F section - includes rubber stop for noise reduction
- U catch horizontally adjustable for ease of lining up to gate frame
- Steel zinc plated



Gate stop

Order Code: XPSG-STOP

- Stops the gate in the option position
- Forged steel zinc plated gate stop with nylon bumper
- Bolts to concrete at end of gate track. 4x Ø11mm fixing holes
- Made in Italy



MATES WITH XP-5800-CSR

Centre support rail top/bottom plate

Order Code: XP-BTP

- Aluminium with countersunk hole machining
- Use to brace off top and/or bottom of centre support rail to top and bottom rails
- Bracing centre support rail provides extra rigidity



Screw top/bottom plate to centre support rail

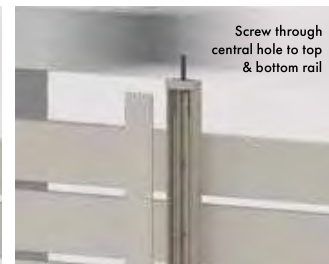

Screw through central hole to top & bottom rail



Gate frame cap

NYLON

Black / Monument / Woodland Grey / Silver / Surfmist / White

Order Code: XP-GFC

- UV stabilised nylon - 3mm thick cap
- Available in 5 colours
- Suits gate side frame
- Press-in flat cap

Finishes



PACK OF 10 Gate frame screws

12Gx65MM HEX FLANGE HEAD

Order Code: XP-SCREWSGF-10PK

- Hex flange head for easy assembly
- Use to screw horizontal top & bottom rails to vertical side frames
- Also use to screw fix 'gate' slat to side frames for horizontal slat gates with 9mm or 20mm spacing (65x16.5mm slats)



Self drilling wafer screws

10Gx16MM - BAG OF 100

Black / Monument / Woodland Grey Silver / Surfmist / White / Basalt Dune / Mill finish

Order Code: XP-SCREWS

- 10G x 16mm self drilling wafer head zinc plated
- Powder coated heads for neat finish
- Use to: (1) Screw fix centre support rail to slats (2) Screw fix & brace off centre support rail top/bottom plate to top/bottom rail (3) Screw fix slats to side frames if required (4) Attach Quickscreen side frame to outer gate frame for gate options 2 & 3 (see pages 89-90)

Sliding gate motors

Your Smart Home
Nice Home

LONG TERM RELIABILITY

NiceHome automation and accessories are tested every day in the Nice laboratories according to strict criteria. To ensure compliance with the strictest safety requirements on the market, NiceHome guarantees the highest possible technological and quality standards.

PROFESSIONAL QUALITY

Designed and manufactured in Italy, NiceHome automation benefits from unique Italian know-how combining top performance with an essential style to adapt perfectly to the needs of your home.

To complement horizontal slat and vertical slat sliding gates, GO can supply the highest quality Italian made gate automation and accessories. NiceHome automation is a new upgrade to the well-known Mhouse range.



Filo 400 Pro Kit

Order Code: XPSG-FILO-400

KIT INCLUDES:

- 1 x Motor
- 2 x Remotes
- 1 x Pair of Photocells (safety device which prevents the gate from closing on pedestrians or vehicles)

- Sliding gate opener suits gates up to 6000mm wide and weighing up to 400kg
- Easy to install and simple programming steps
- Flexible short power cord pre-wired to motor
- Plugs into standard power point with 10 amp flat 3 pin plug
- Includes pinion (cog) that integrates with rack on gate

Low voltage cable option



External transformer

FILO 400 Pro Kit with split pack Features external transformer

Order Code: XPSG-FILO-400PRO-SP

- Same motor and accessories as FILO 400 except transformer is separated from motor
- External transformer converts 240V mains power to low voltage 24V
- Use 2 core x 2.5mm (double insulated) electrical cable to run from transformer to motor. CABLE SOLD SEPARATELY - can be purchased from electrical wholesaler or reputable hardware store
- Motor can be installed a maximum of 50 meters away from transformer 10 amp flat 3 pin plug
- Ideal where getting 240V mains power to gate motor is different. Simply run low voltage cable from transformer to gate motor.
- Refer www.easygate.com.au for technical assistance/manuals

KIT INCLUDES:

- 1 x Motor
- 2 x Remotes
- 1 x Pair of Photocells (safety device which prevents the gate from closing on pedestrians or vehicles)
- 1 x External transformer in weatherproof enclosure

MOTOR ACCESSORIES



Remote control

Order Code: XPSG-FILO-REMOTE

- Optional extra remote control to replace remotes in kit if broken or more remotes required (2x remotes included as standard with each motor kit)
- 5 channel remote able to control various gate functions (eg open only, close only, partial open etc)



Wireless keypad

Order Code: XPSG-FILO-WKP

- Optional wireless keypad for gate motor opening/closing
- PIN number control access
- Easy to affix to wall or post
- Runs on 2 x CR2430 lithium batteries



Solar power kit

Order Code: XPSG-FILO-SOLAR

- Solar power system designed for use with NiceHome motors
- System uses exclusively solar power to run automation without use of electrical mains power
- Provides continuous electrical energy. Ideal for sites where mains power is unavailable
- Includes photovoltaic panel (converts solar energy into electrical energy) and electric battery (for stored power, able to operate gate night and day)
- Attention must be paid to ensure panel positioned to receive full sunshine



Backup battery

Order Code: XPSG-FILO-BATTERY

- Optional battery provides backup power in the event of mains power failure
- Gate can be cycled multiple times under battery power (no. of cycles may vary due to gate size and site conditions)
- Backup battery is recharged under mains power



Rack

Order Code: XPSG-FILO-RACK

- Tough 8 durable nylon rack (with steel core)
- Affix to bottom rail of sliding gate
- 1 meter long sections; 6 fixing points
- Quieter than steel racks
- Made in Italy



TECHNICAL ASSISTANCE/MANUALS AND SUPPORT VIDEOS

www.easygate.com.au